



Diavia

RENAULT "MASTER"

3000 DCI "136HP"

3000 DXI "156HP"

(MOTORE TRASVERSALE)

(MOTEUR TRANSVERSAL)

(TRANSVERSE MOTOR)

(TRANSVERSALMOTOR)

(MOTOR TRANSVERSAL)

Codice/Code: 1RE20100E + A03988

**Istruzioni montaggio
condizionatore d'aria**

**Instructions pour monter le
conditionneur d'air**

**Air conditioning
installation instructions**

**Klimaanlage
Einbauanleitungen**

**Instrucciones para el montaje
del equipo aire acondicionado**

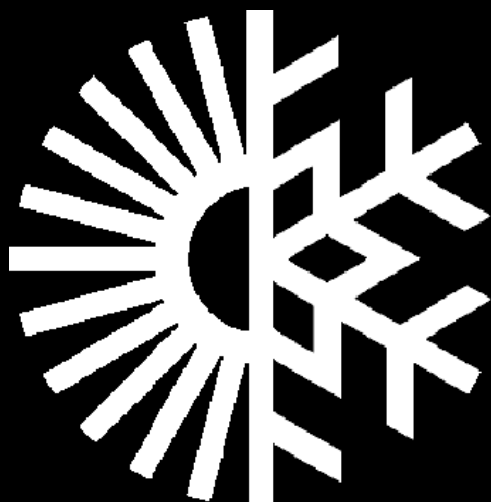

**DESCRIZIONE SIMBOLOGIA UTILIZZATA / DESCRIPTION DE LA SYMBOLOGIE UTILISÉE
DESCRIPTION OF SYMBOLS USED / BESCHREIBUNG DER VERWENDETEN SYMBOLIK
DESCRIPCIÓN DE LOS SIMBOLOS UTILIZADOS**

1A

Riferimento a figura / Référence à la figure / See figure
In Bezug auf Abbildungen / Referencia a la figura

1- 1

Riferimento a componenti di fornitura / Référence aux composants de la fourniture
See supplied components / Bezug auf Gelieferte Einbauelemente
Referencia a los componentes de abastecimiento

1

Riferimento a posizione schema elettrico / Référence à la position du schéma électrique
See position in wiring diagram / In Bezug auf Position im Schaltschema /
Referencia a la posición del esquema eléctrico



- Lubrificare tutti i raccordi e gli O.R. con il nuovo olio refrigerante prima di collegarli
- Graisser tous les raccords et les O.R. avec le nouveau huile réfrigérant avant de les raccorder

-Lubricate all fittings and O-rings with new refrigerant oil before connecting them

- Alle Verbindungsstücke und OR-Ringe vor deren Verbindung mit dem neuen Kühlmittellöl ölen

- Lubrificar todos los empalmes y los O.R. con el nuevo aceite refrigerante antes de conectarlos

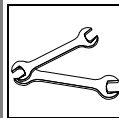

- Per avvitar a fondo o allentare i raccordi tubi gas usare due chiavi per bilanciare coppia di torsione
- Pour visser à fond ou desserrer les raccords des tuyaux gaz, utiliser le deux clés pour équilibrer le couple de torsion

- When tightening or loosening the fittings of the gas pipes, use two wrenches to equalize the torsion couple

- Um die Verbindungsstücke der Kältemittelschläuche gleichmäßig festzuschrauben oder zu lockern, zwei Schlüssel für das Verschraubungspaar verwenden

- Para enroscar a fondo o aflojar los empalmes tubos gas se deben usar dos llaves para balancear el par de torsión



- Tagliare con utensile appropriato al materiale
- Couper à l'aide d'outil approprié
- Cut with a device suitable for the material



- Mit dem Material entsprechendem Werkzeug schneiden
- Cortar con herramienta apropiada al material

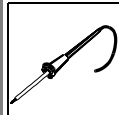

- Stagnare
- Étamer
- Tin
- Verzinnen
- Estañar



- Spianare
- Nivelar
- Flatten out
- Richten
- Nivelar

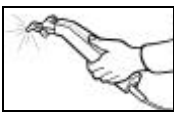

- Tagliare con utensile a lama calda
- Couper à l'aide d'un outil à lame chaude
- Cut using the tool with heated blade.
- Mit Schweißmesserwerkzeug schneiden
- Cortar con útil a hoja caliente

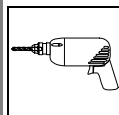

- Forare
- Percer
- To drill
- Durchbohren
- Taladrar

Pos.	ITALIANO	FRANÇAIS	ENGLISH	DEUTSCH	ESPAÑOL
1	Compressore	Compresseur	Compressor	Kompressor	Compresor
1.1	Cablaggio Packard per compressore	Câblage Packard pour compresseur	Packard wiring for compressor	Packard Kabelstrang für Kompressor	Cableado Packard para compresor
31	Condensatore	Condenseur	Condenser	Kondensator	Condensador
32	Staffa sinistra di supporto condensatore	Etrier support condenseur gauche	Left condenser support bracket	Kondensator-Haltebügel, links	Abrazadera izquierda de soporte condensador
33	Staffa destra di supporto condensatore	Etrier support condenseur droit	Right condenser support bracket	Kondensator-Haltebügel, rechts	Abrazadera derecha de soporte condensador
34	Sacchetto accessori	Sachet accessoires	Bag of accessories	Säckchen mit Zuberhörteilen	Bolsita accesorio
35	Elettroventola	Electroventilateur	Electric fan	Elektrogebläse	Electroventilador
36	Convogliatore elettroventola	Convoyeur ventilateur	Electric fan conveyor	Elektrogebläse Luftförderer	Transportador electroventilador
37	Inserito filettato M6	Pièce d'insertion filetée M6	Threaded insert M6	Gewindeinsatz M6	Encastre fileteado M6
38	Resistore	Résisteur	Resistor	Widerstand	Resistor
40	Sacchetto accessori	Sachet accessoires	Bag of accessories	Säckchen mit Zuberhörteilen	Bolsita accesorio
41	Staffa di supporto tubi gas	Etrier support des tuyaux gaz	Gas pipe support bracket	Kältemittelschlauch-Haltebügel	Abrazadera de soporte tubos gas
42	Fascetta in gomma	Collier en caoutchouc	Rubber clamp	Gummischelle	Banda de goma
43	Raccordo per bulbo termostatico	Raccord pour bulbe thermostatique	Thermoswitch coupling	Thermostatkolbenverbindung	Récord bulbo termostático
44	Bulbo termostatico	Bulbe thermostatique	Thermoswitch	Thermostatschalter	Bulbo termostático
45	Rondella per bulbo termostatico	Rondelle pour bulbe thermostatique	Thermoswitch coupling	Scheibe für den Thermostatkolben	Arandela para bulbo termostático
46	Fascetta	Collier	Clamp	Schelle	Banda
47	Sacchetto flangia	Sachet bride	Bag of flanges	Säckchen mit Flansch	Bolsita brida
48-49 50	Fermatubo	Fixation tuyau	Pipe clamp	Schlauchbinder	Detiene tubo
51	Staffa filtro	Etrier filtre	Receiver drier bracket	Filterbügel	Abrazadera filtro
52	Inserito filettato M6	Pièce d'insertion filetée M6	Threaded insert M6	Gewindeinsatz M6	Encastre fileteado M6
53	Filtro essiccatore	Filtre déshydrateur	Receiver drier	Trocknerfilter	Filtro secador
54	Pressostato	Pressostat	Pressure switch	Druckwächter	Presostato
55	Protezione a spirale	Protection en spirale	Spiral protection	Spiralförmige Ummantelung	Protección a espiral
56	Fascetta in gomma	Collier en caoutchouc	Rubber clamp	Gummischelle	Banda de goma
61	Batteria evaporante	Batterie évaporateur	Evaporating unit	Verdampferbatterie	Batería evaporante
61.1	Graffetta a molla per vite autofilettante	Agrafe à ressort pour vis autotaradeuse	Spring clip for self-tapping screw	Federklammer für selbstschneidende Schraube	Grapa a muelle para tornillo autorroscante
62	Sacchetto accessori	Sachet accessoires	Bag of accessories	Säckchen mit Zuberhörteilen	Bolsita accesorio
63	Staffa fissaggio batteria evaporante	Etriere de fixation batterie évaporateur	Evaporating unit fixing bracket	Verdampferbatterie-Befestigungshalter	Soporte de fijación batería evaporante
64	Valvola di espansione	Soupape d'expansion	Expansion valve	Expansionsventil	Válvula expansión
65	Flangia fissaggio valvola	Bride de fixation soupape	Valve fixing flange	Ventil-Befestigungsflansch	Brida de fijación de la válvula

Pos.	ITALIANO	FRANÇAIS	ENGLISH	DEUTSCH	ESPAÑOL
66	Tubo scarico condensa	Tuyau d'écoulement des condensations	Condensate drain pipe	Kondenswasserabfußschlauch	Tubo descarga condensación
67	Staffa supporto termostato	Etrier supportthermostat	Thermostat support bracket	Thermostat-Haltebügel	Abrazadera soporte termostato
68	Termostato	Thermostat	Thermostat	Thermostat	Termostato
69	Molla fissaggio bulbo	Ressort fixation bulbe	Thermoswitch fixing spring	Kolben-befestigungsfeder	Muelle de fijación del bulbo
70	Mastice anticondensa	Mastic anti-condensation	Condensation-proofing material	Kondenswasserdichtmasse	Masilla anticondensación
71	Porta-interruttore	Porte-interrupteur	Switch plate	Schalter-Halter	Porta interruptor
72	Copriforo	Couvre-trou	Hole cap	Bohrungsabdeckung	Cubre orificio
73	Interruttore di comando A.C.	Interrupteur de commande A.C.	A.C. control switch	Klimaanlagenschalter	Interruptor de comando A.C.
91	Impianto elettrico comandi	Faisceau électrique commandes	Electrical system for controls	Elektrische Anlage der Bedienungseinheit	Instalación eléctrica comandos
92	Giunzione RAYCHEM BLU	Raccord RAYCHEM BLEU	BLUE RAYCHEM connector	RAYCHEM Verbindung BLAU	Junta RAYCHEM TURQUI
93	Giunzione RAYCHEM GIALLA	Raccord RAYCHEM JAUNE	YELLOW RAYCHEM connector	RAYCHEM Verbindung GELB	Junta RAYCHEM AMARILLO
94	Circuito illuminazione	Circuit de l'éclairage	Lighting circuit	Bleuchtungsstromkreis	Circuito de iluminación
95	Connettore 5 vie	Connecteur à 5 voies	5-way connector	5-weg-Steckverbinder	Conector 5 vías
106	Impianto elettrico Elettroventole	Installation électrique electroventilateurs	Fans electric system	Elektrische Anlage Elektrolüfter	Instalación eléctrica electroventiladores
107	Giunzione RAYCHEM GIALLA	Raccord RAYCHEM JAUNE	YELLOW RAYCHEM connector	RAYCHEM Verbindung GELB	Junta RAYCHEM AMARILLO
108	Giunzione RAYCHEM BLU	Raccord RAYCHEM BLEU	BLUE RAYCHEM connector	RAYCHEM Verbindung BLAU	Junta RAYCHEM TURQUI
	Fascetta a strappo	Bride auto-bloquant	Self-locking clamp	Selbstsichernde Schelle	Banda autobloqueante
	Tubo gas 5/16"CF (condensatore-filtro)	Tuyau gaz 5/16"CF (condenseur-filtre)	5/16"CF gas hose (condenser-filter)	5/16"CF kaeltemittelschlauch (Kondensator-Filter)	Tubo gas 5/16"CF (condensador-filtro)
	Tubo gas 5/16"FE (filtro-evaporatore)	Tuyau gaz 5/16"FE (filtre-évaporateur)	5/16"FE gas hose (filter-evaporator)	5/16"FE kaeltemittelschlauch (Filter-Verdampfer)	Tubo gas 5/16"FE (filtro-evaporador)
	Tubo gas 13/32"CC (compressore-condensatore)	Tuyau gaz 13/32"CC (compresseur-condenseur)	13/32"CC gas hose (compressor-condenser)	13/32"CC kaeltemittelschlauch (Kompressor-Kondensator)	Tubo gas 13/32"CC (compresor-condensador)
	Tubo gas 1/2"EC (evaporatore-compressore)	Tuyau gaz 1/2"EC (évaporateur-compresseur)	1/2"EC gas hose (evaporator-compressor)	1/2"EC kaeltemittelschlauch (Verdampfer-Kompressor)	Tubo gas 1/2"EC (evaporador-compresor)



**MONTAGGIO COMPRESSORE / POSE DU COMPRESSEUR / COMPRESSOR FITTING
KOMPRESSOREINBAU / MONTAJE COMPRESOR**

MATERIALE FORNITO / MATERIEL FOURNI / SUPPLIED MATERIAL / GELIEFERTES MATERIAL / MATERIAL ABASTECIDO

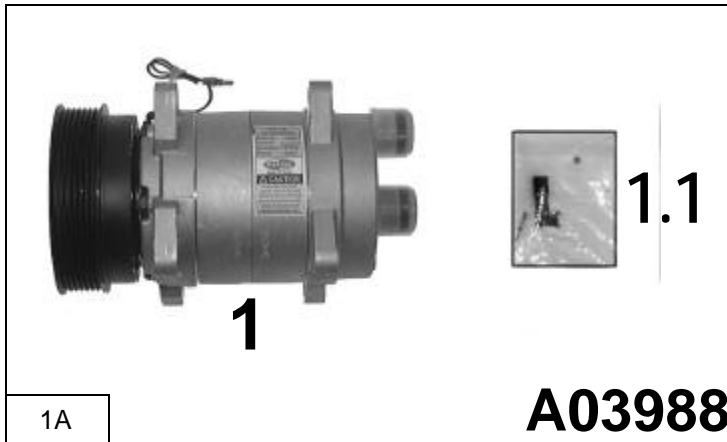

Pos.	Descrizione / Description / Description Beschreibung / Descripción	Codice / Code Code / Código
1	Compressore	014389/0
1.1	Cablaggio Packard per compressore	0282113/1

**OPERAZIONI PRELIMINARI / OPERATIONS PRELIMINAIRES / PRELIMINARY OPERATIONS
VORBEREITUNGSARBEITEN / OPERACIONES PRELIMINARES**

(I)

- Scollegare la batteria.

SMONTARE:

- mascherina frontale.
- paraurti.
- indicatori di direzione e fanali anteriori.
- assieme radiatore-intercooler-elettroventola.
- grembialina inferiore di protezione motore.

(F)

- Déconnecter la batterie.

DÉPOSER:

- La plaque frontale.
- Les pare-chocs.
- Les feux de direction et les feux avant.
- L'ensemble radiateur-intercooler-électroventilateur.
- Le volet inférieur de protection du moteur.

(GB)

- Disconnect the battery.

REMOVE:

- front radiator grill.
- bumpers.
- directionals and headlights.
- radiator-intercooler-electric fan assembly.
- lower engine protection screen.

(D)

- Batterie abklemmen.

AUSBAU:

- Kühlerverkleidung.
- Stoßstange.
- Winker und vordere Scheinwerfer.
- Untere Motorabdeckung.
- Antriebsriemen Drehstromgenerator-Servolenkung.

(E)

- Desconectar la batería

DESMONTAR:

- Mascarilla frontal.
- Paragolpes.
- Indicadores de dirección y faros anteriores.
- Conjunto radiador-intercooler-electroventilador.
- Pantalla inferior de protección motor.

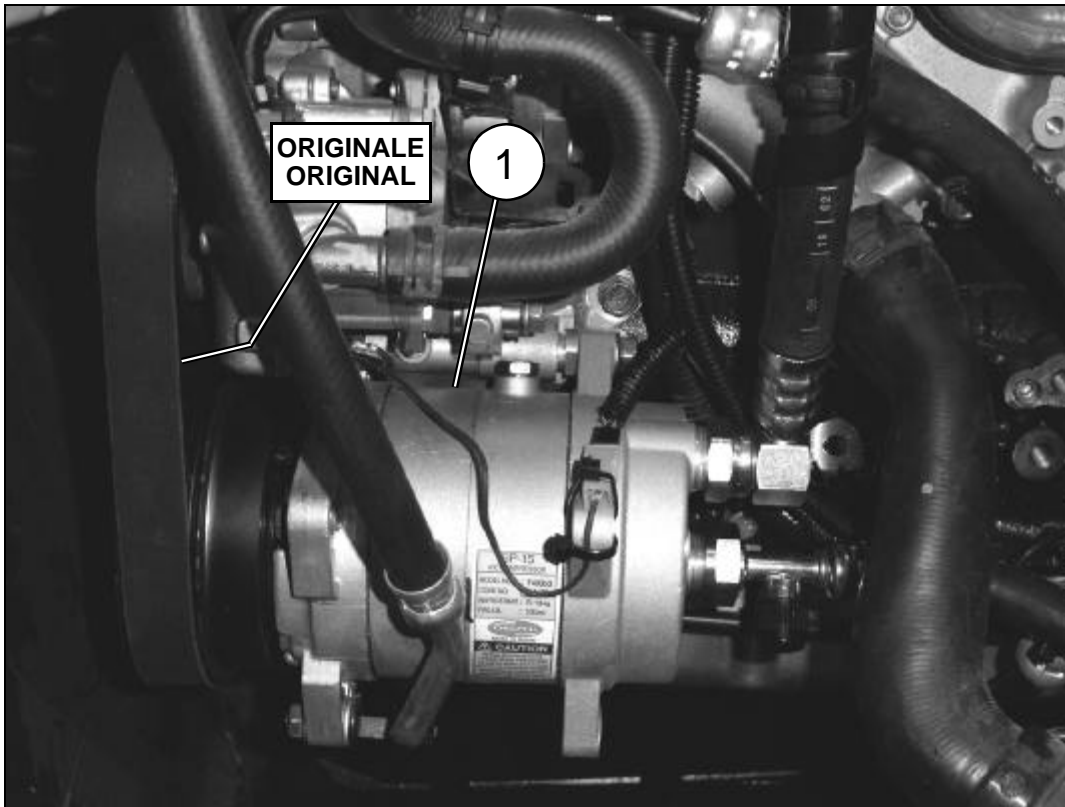

(I) Smontare e conservare la cinghia di trasmissione.

Smontare ed eliminare dal blocco motore la puleggia galloppino e relativo supporto, presente nella zona inferiore alla pompa idroguida (conservare la bulloneria di fissaggio).

Montare il compressore fornito "1", fissandolo alle predisposizioni del blocco motore mediante bulloneria originale.

Rimontare la cinghia di trasmissione originale.

(F) Déposer et conservar la courroie de transmission.

Déposer et éliminer du groupe moteur la poulie de renvoi avec le correspondant support situé dans la partie inférieure de la pompe direction assistée (conservar la boulon-

Poser le compresseur fournie "1", et le fixer aux éléments prédisposés dans le groupe moteur à l'aide de la boulonnerie d'origine.

Reposer la courroie de transmission d'origine.

(GB) Remove the transmission belt and set it aside.

In the lower area of the hydraulic power steering pump, remove the idle pulley and its support and eliminate them (keep the securing nuts and bolts).

Install the supplied compressor "1" securing it to the arrangement on the engine block using the original nuts and bolts.

Return the transmission belt to its original position.

(D) Antriebsriemen ausbauen und aufbewahren.

Vom Motorblock die Leitrollenriemenscheibe und entsprechende im unteren Bereich an der Servolenkungspumpe vorhandene Halterung ausbauen und entfernen (Befestigungsschraubensatz aufbewahren).

Gelieferten Kompressor "1" einbauen und an werkseitig vorhandene Punkte am Motorblock mit Original-Schraubensatz festschrauben.

Original-Antriebsriemen wieder einbauen.

(E) Desmontar y conservar la correa de transmisión.

Desmontar y eliminar del bloque motor la polea directriz y el correspondiente soporte que hay en la zona inferior de la bomba servodirección (conservar los tornillos de fijación).

Montar el compresor abastecido "1" y fijarlo a la predisposición del bloque motor con los tornillos originales.

Volver a montar la correa de transmisión original.

2A

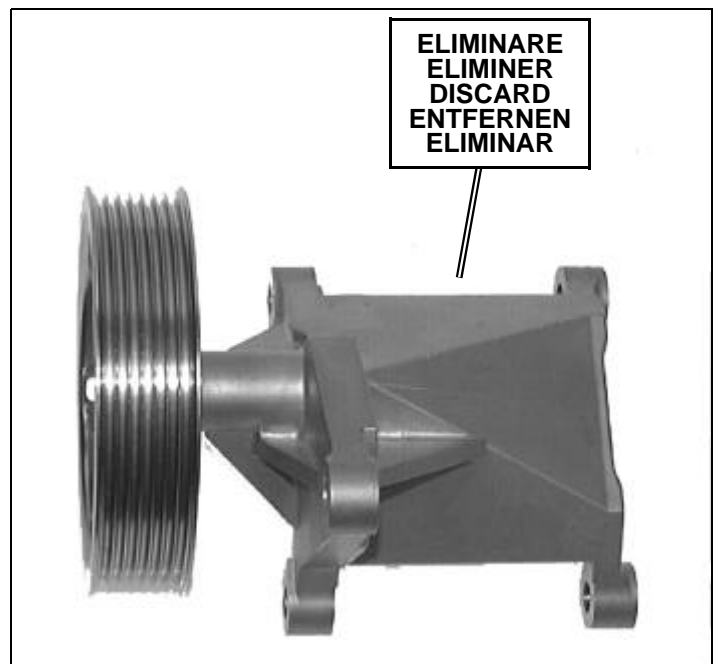

**MONTAGGIO CONDENSATORE / POSE DU CONDENSEUR / CONDENSER FITTING
KONDENSATOREINBAU / MONTAJE CONDENSADOR**

MATERIALE FORNITO / MATERIEL FOURNI / SUPPLIED MATERIAL / GELIEFERTES MATERIAL / MATERIAL ABASTECIDO

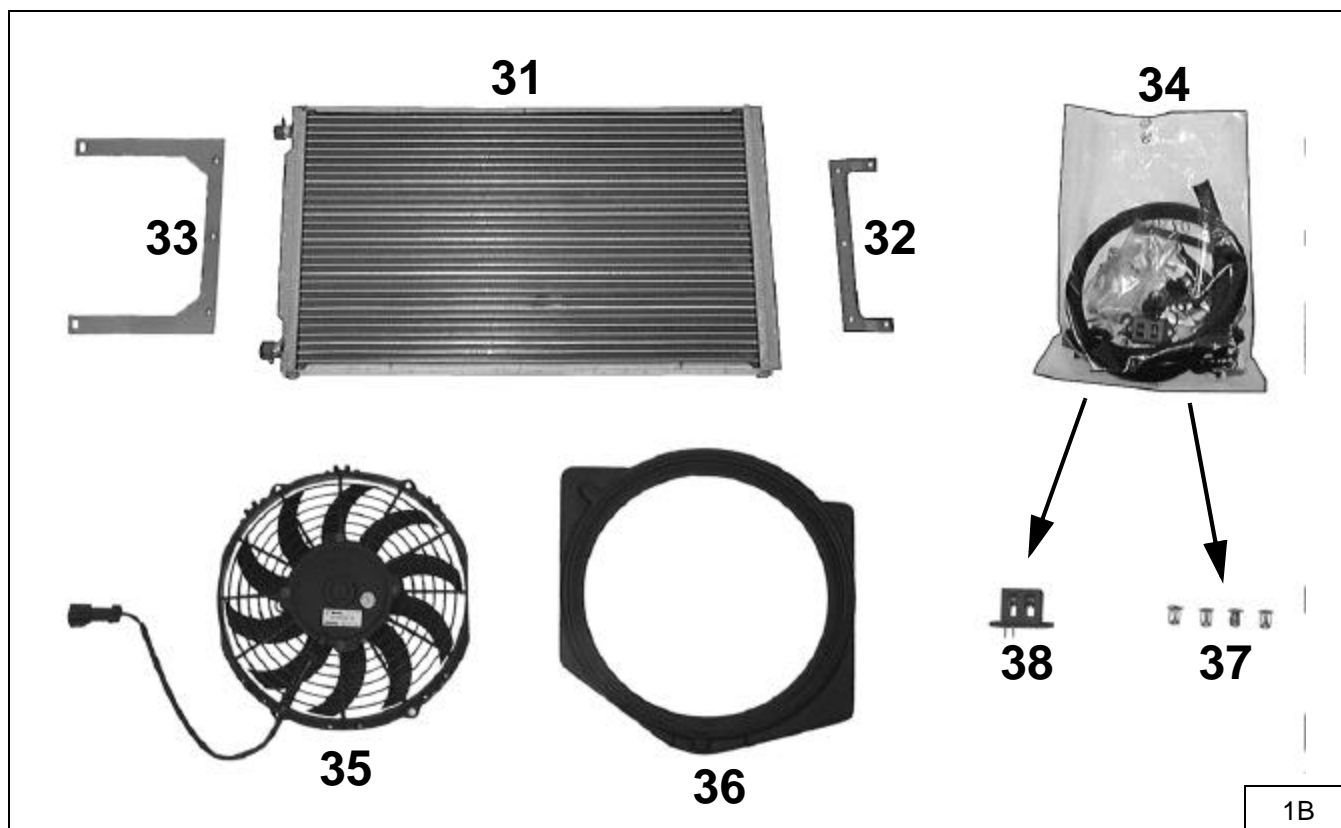

Pos.	Descrizione / Description / Description Beschreibung / Descripción	Codice / Code Kode / Código
31	Condensatore	022301OR/1
32	Staffa sinistra di supporto condensatore	0812496/0
33	Staffa destra di supporto condensatore	0812585/0
34	Sacchetto accessori	0231663/0
35	Elettroventola	080157/0
36	Convogliatore elettroventola	083179/0
37	Insero filettato M6	062089/0
38	Resistore	0681112/2

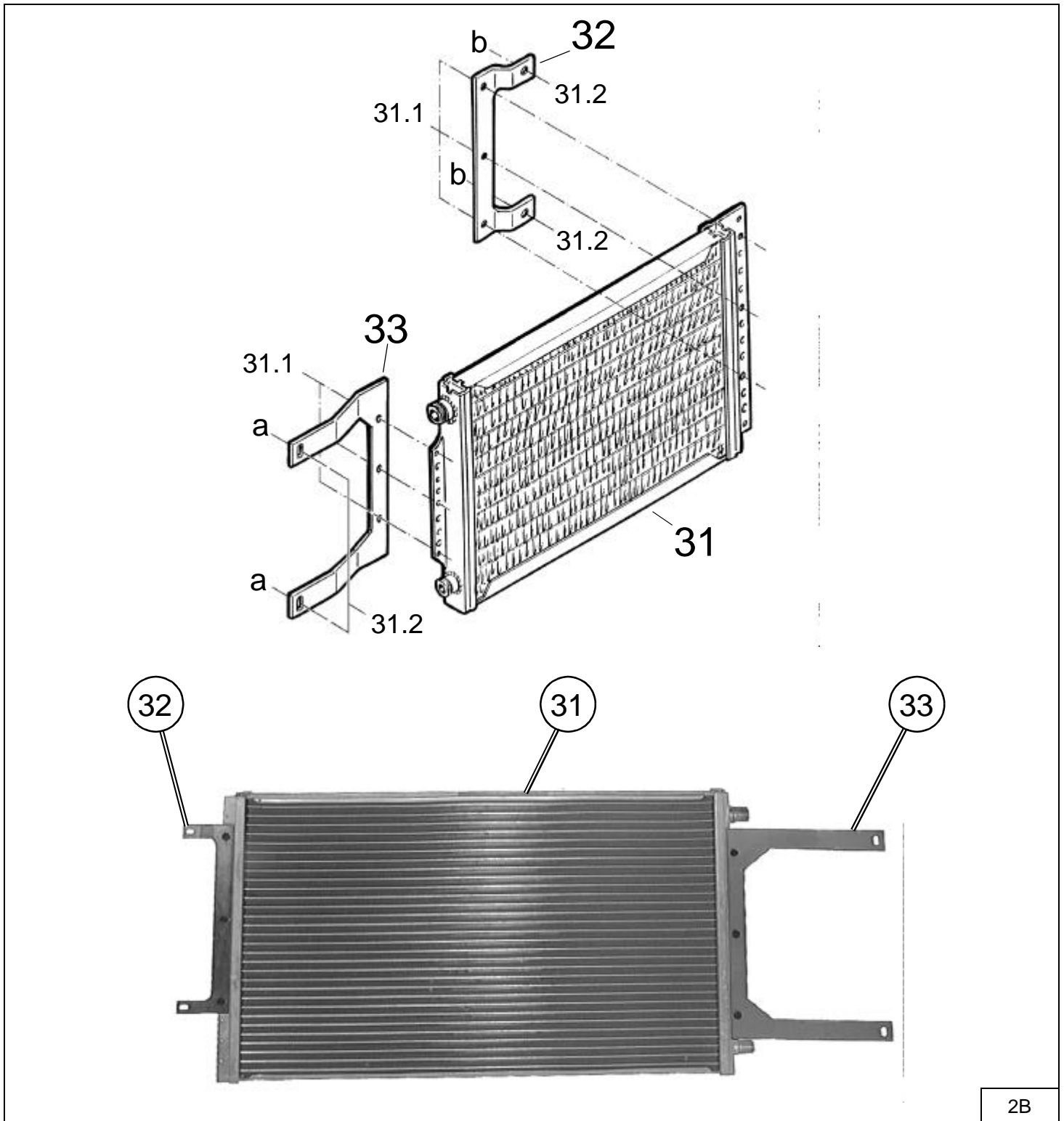

2B

ELEMENTI DI FISSAGGIO / PIECES DE FIXATION / FIXING PARTS BEFESTIGUNGSELEMENTE / ELEMENTOS DE FIJACION		
Pos.	Tipologia / Typologie / Typology Tipologie / Tipologia	Descrizione / Description / Description Beschreibung / Descripción
31.1		4,2x13
31.2		4,8x13

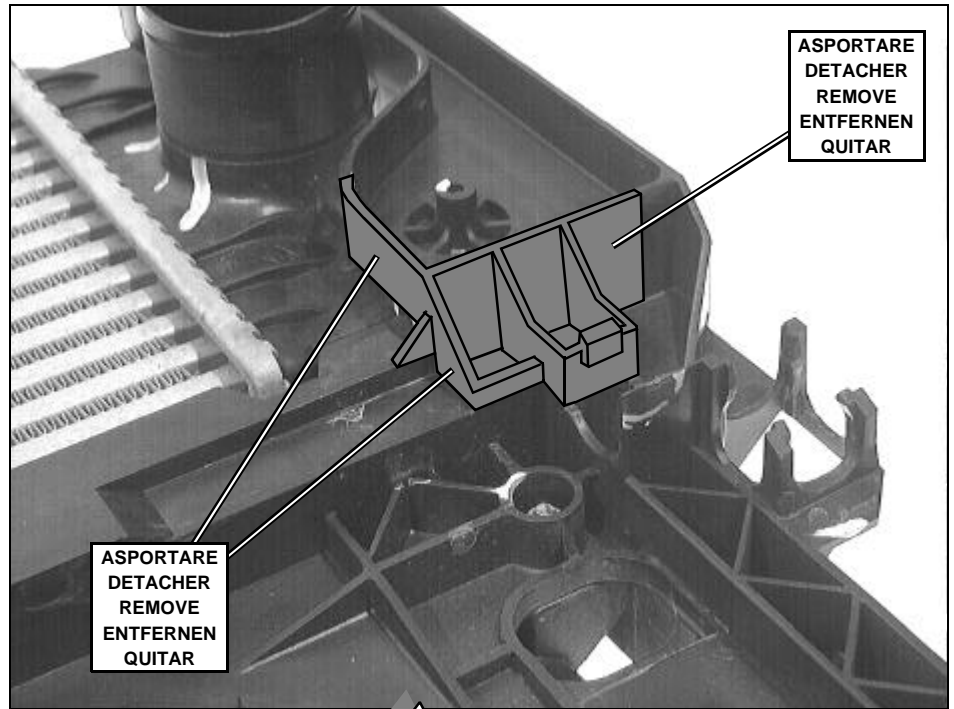

ORIGINALE
ORIGINAL

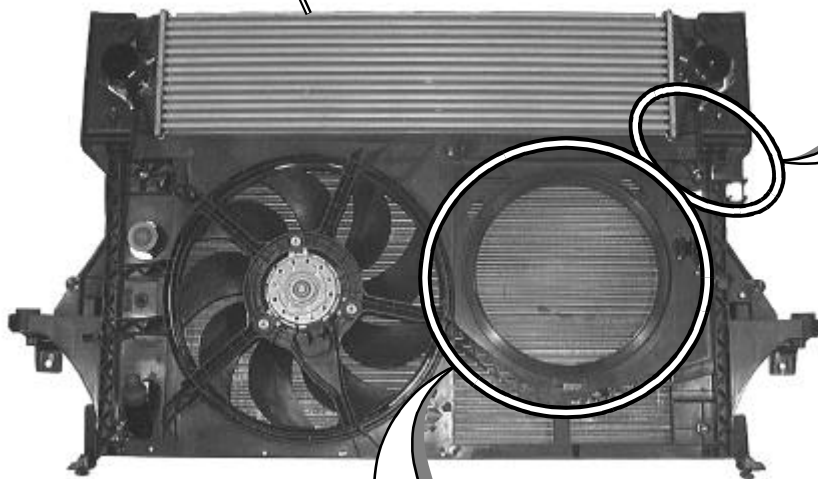

3B

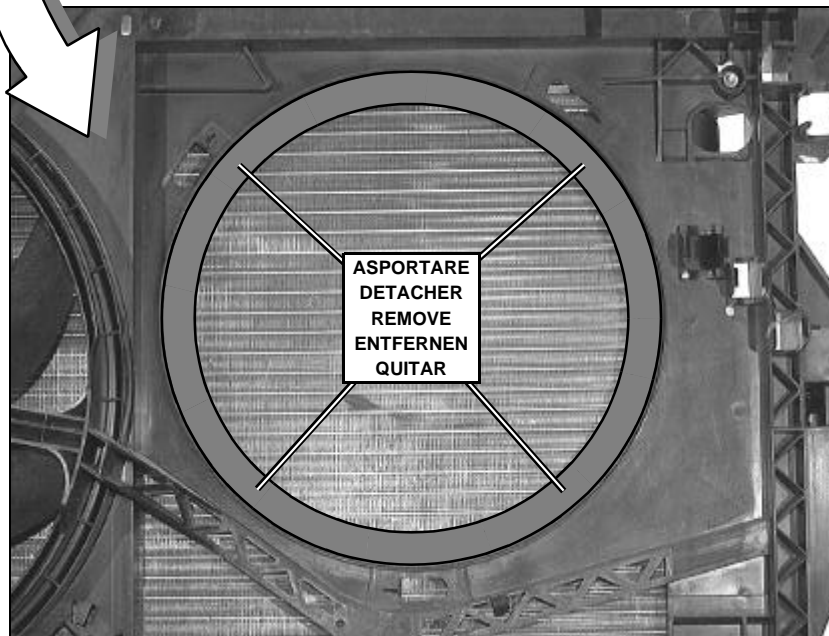

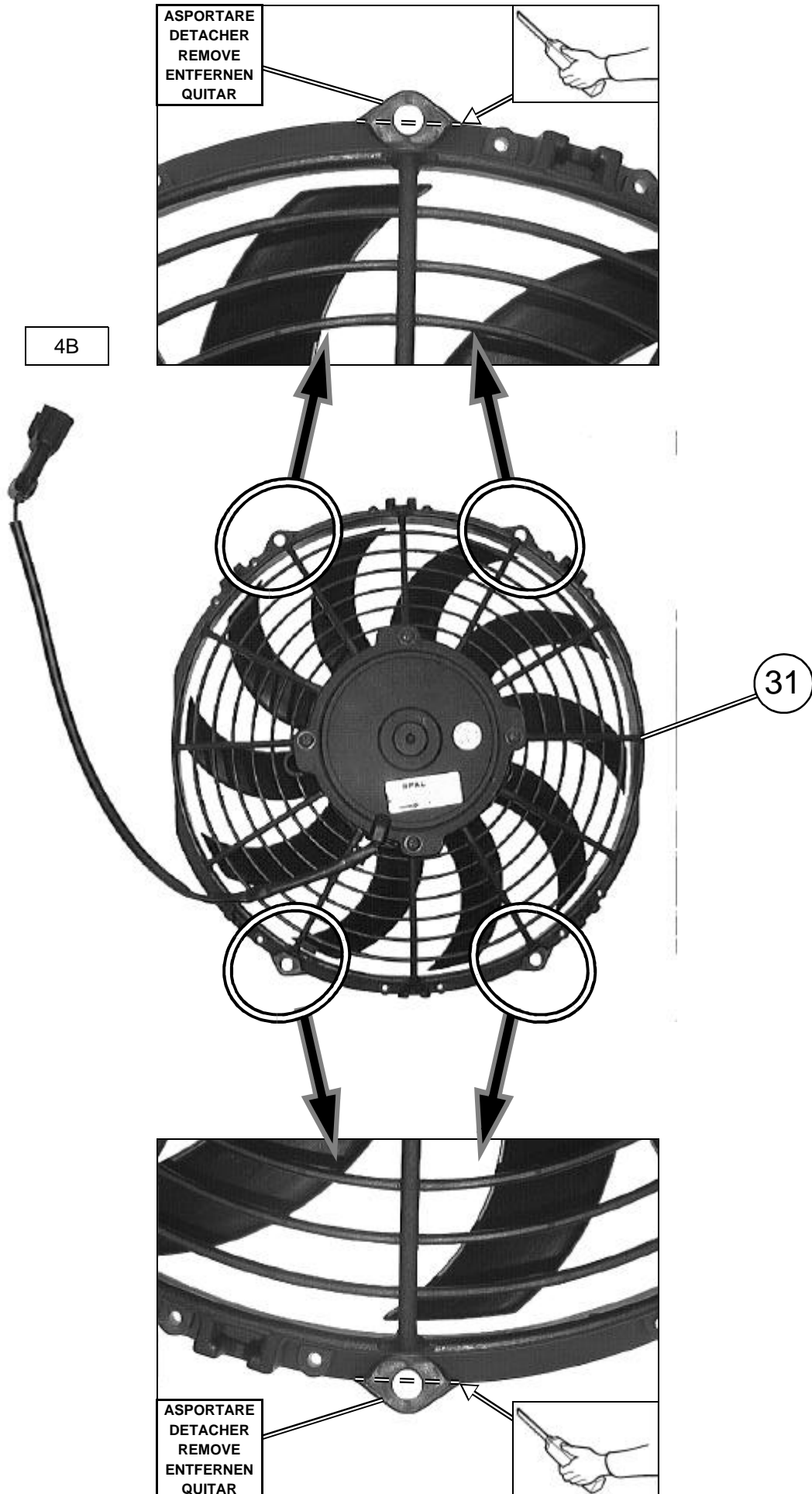

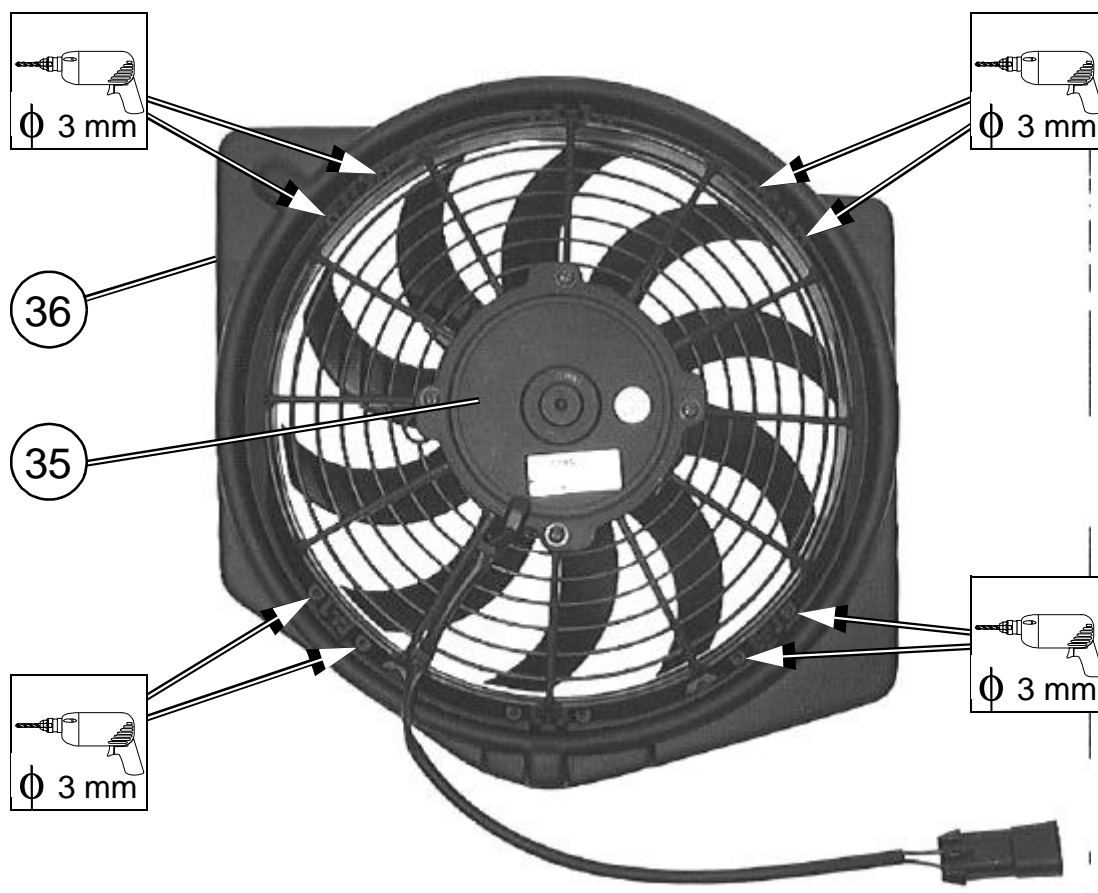

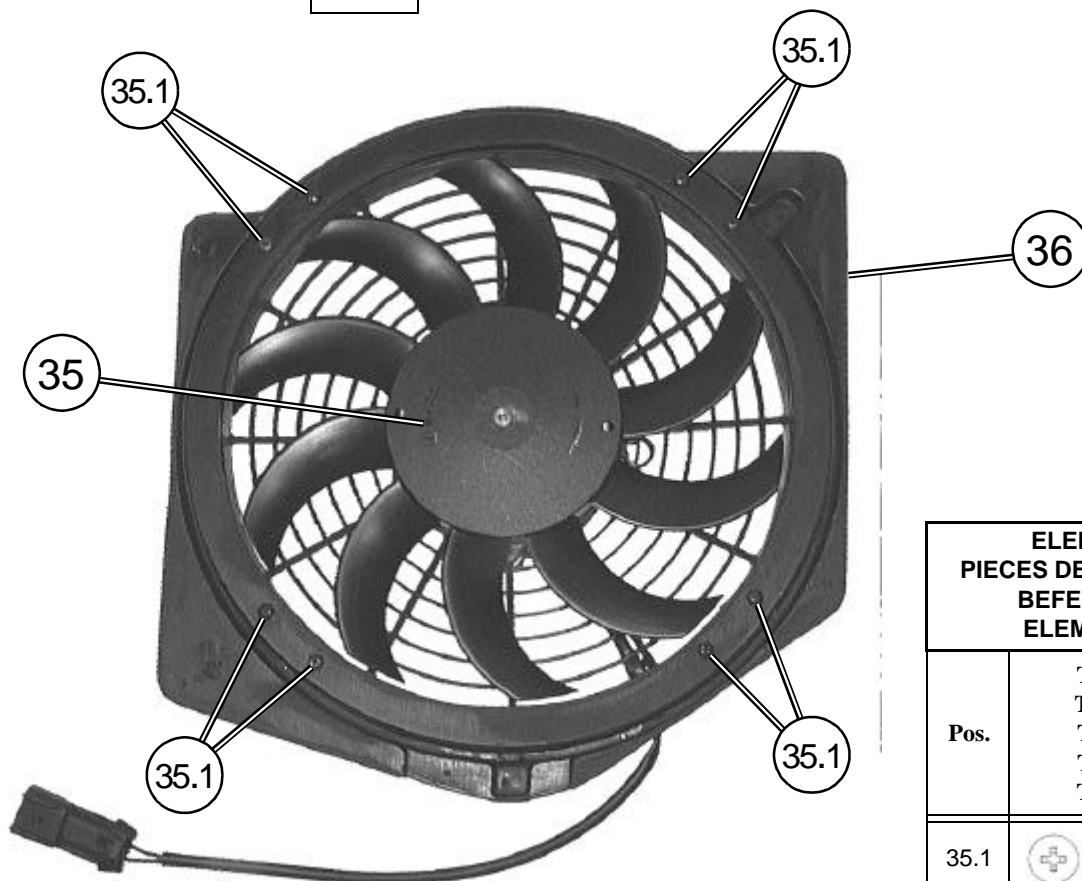

5B



ELEMENTI DI FISSAGGIO PIECES DE FIXATION / FIXING PARTS BEFESTIGUNGSELEMENTE ELEMENTOS DE FIJACION		
Pos.	Tipologia Typologie Typology Tipologie Tipologia	Descrizione Description Description Beschreibung Descripción
35.1	 	3,9x19

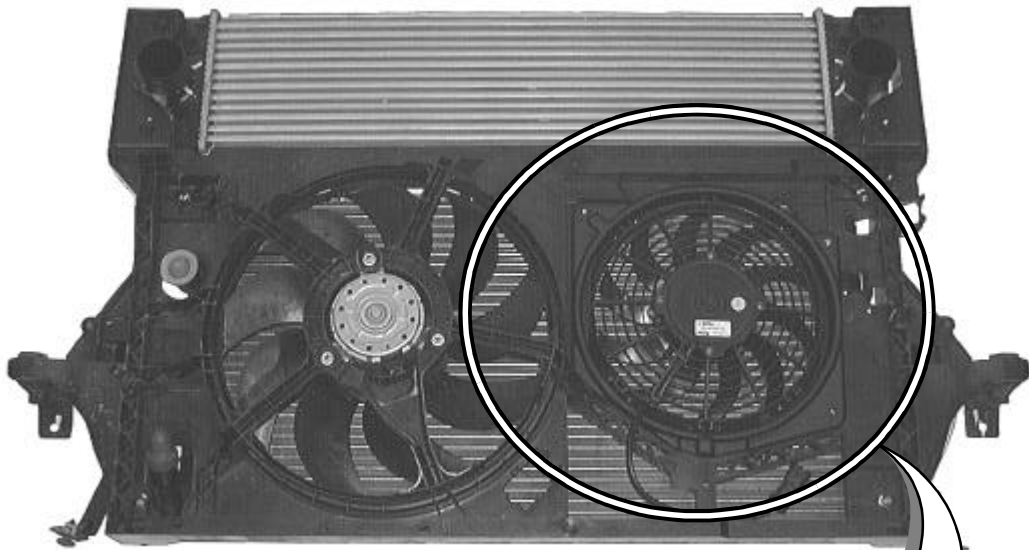

6B

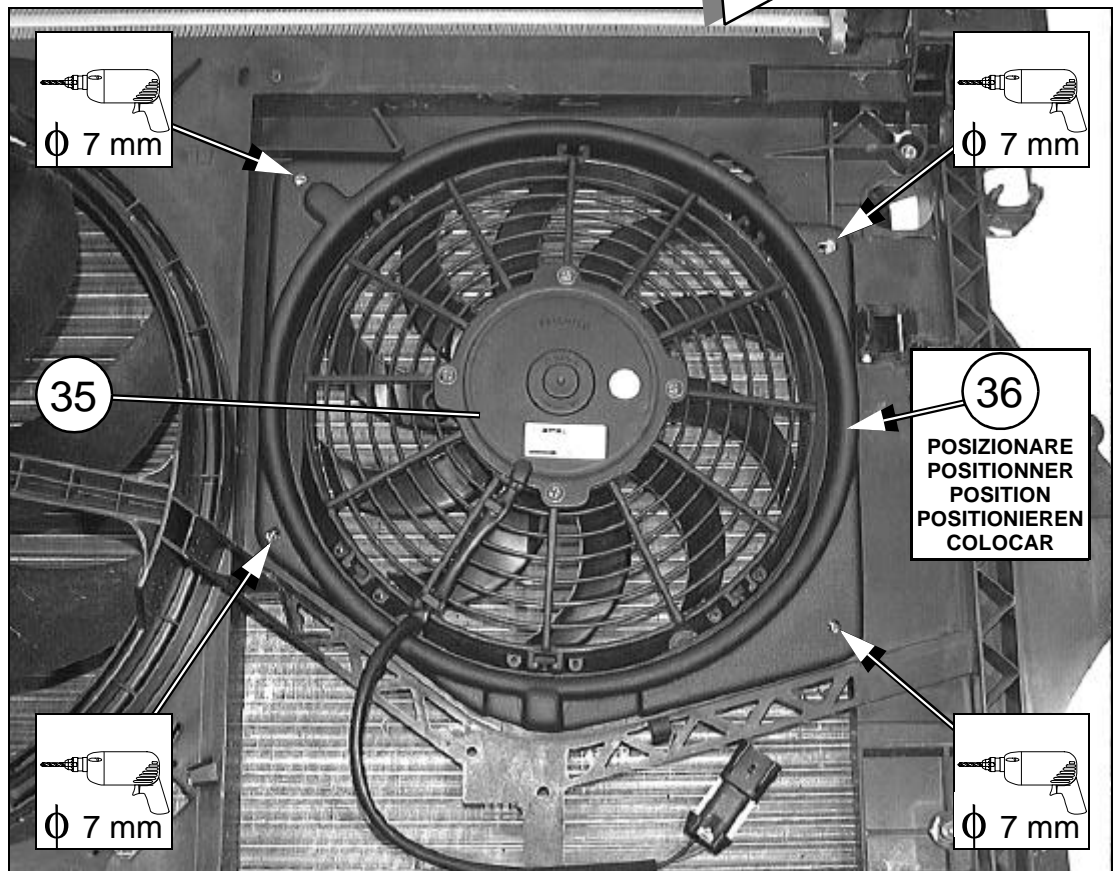

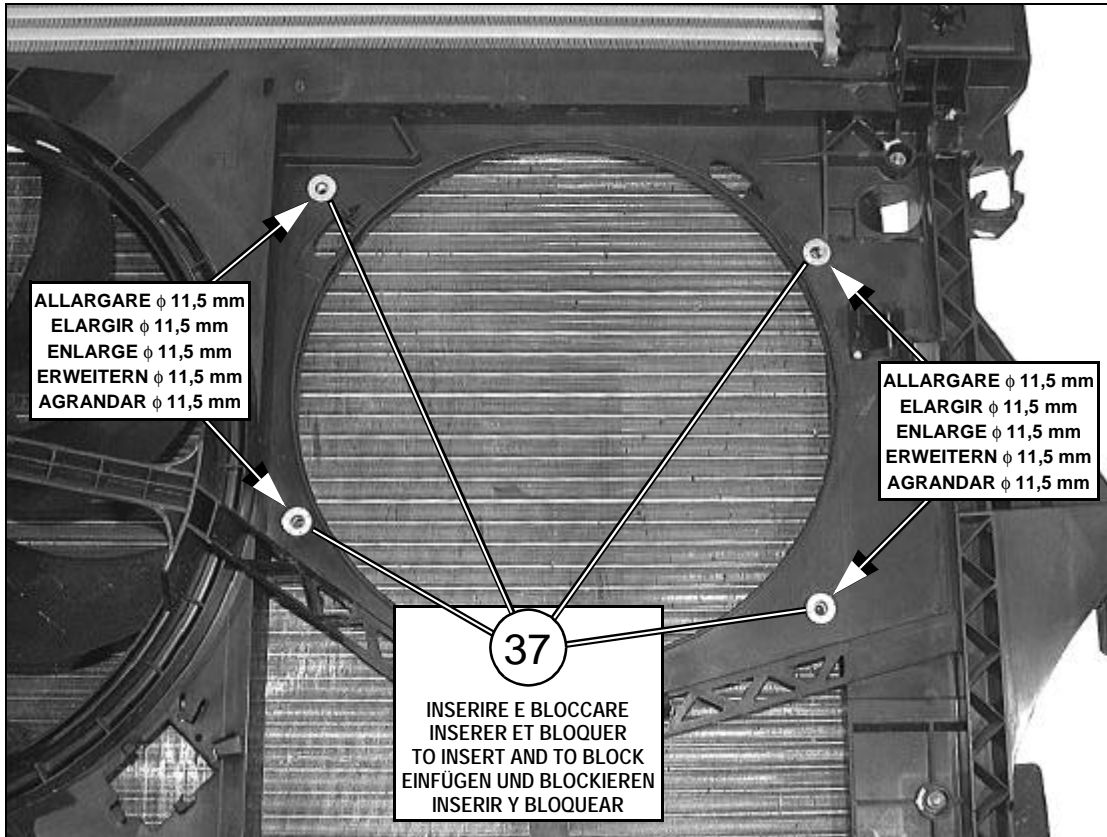

7B

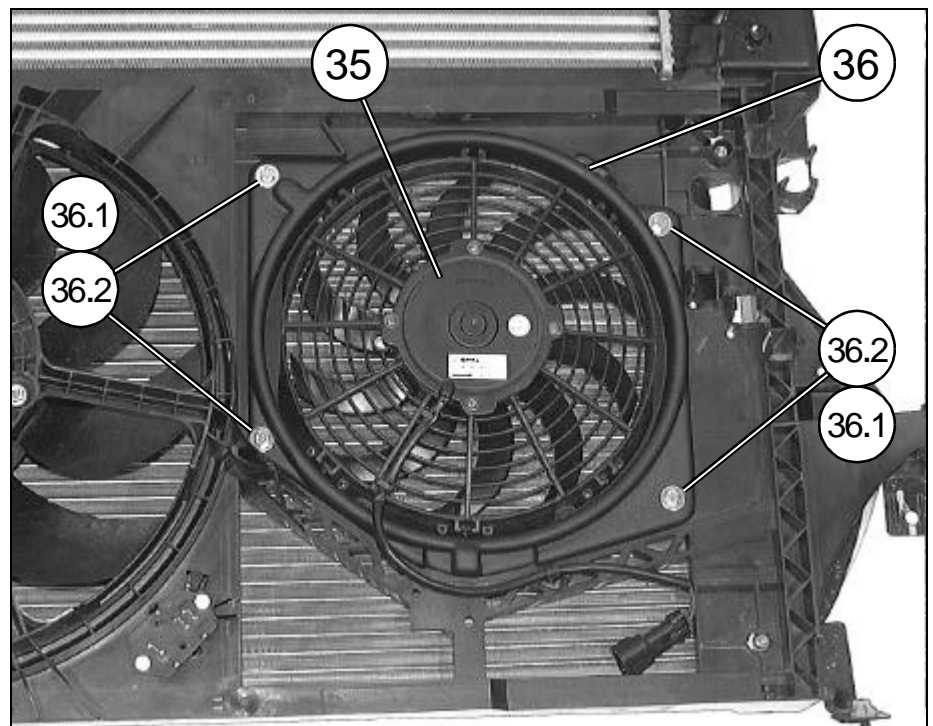

ELEMENTI DI FISSAGGIO / PIECES DE FIXATION / FIXING PARTS BEFESTIGUNGSELEMENTE / ELEMENTOS DE FIJACION		
Pos.	Tipologia / Typologie / Typology Tipologie / Tipologia	Descrizione / Description / Description Beschreibung / Descripción
36.1		M6x20
36.2		ϕ 6x ϕ 18x2

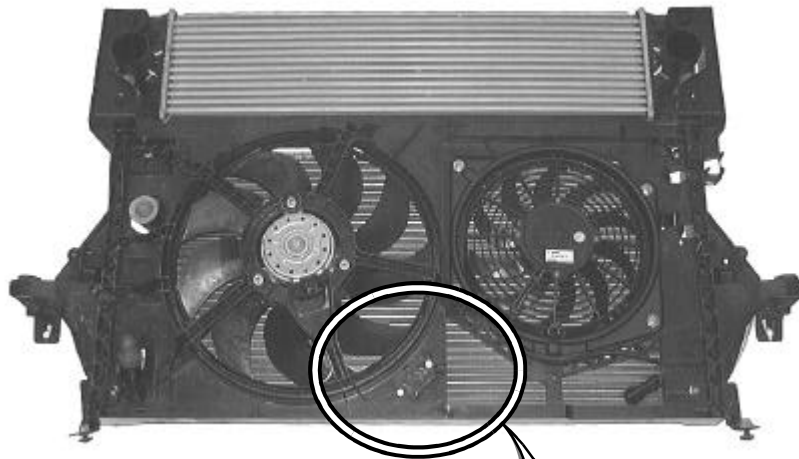

8B

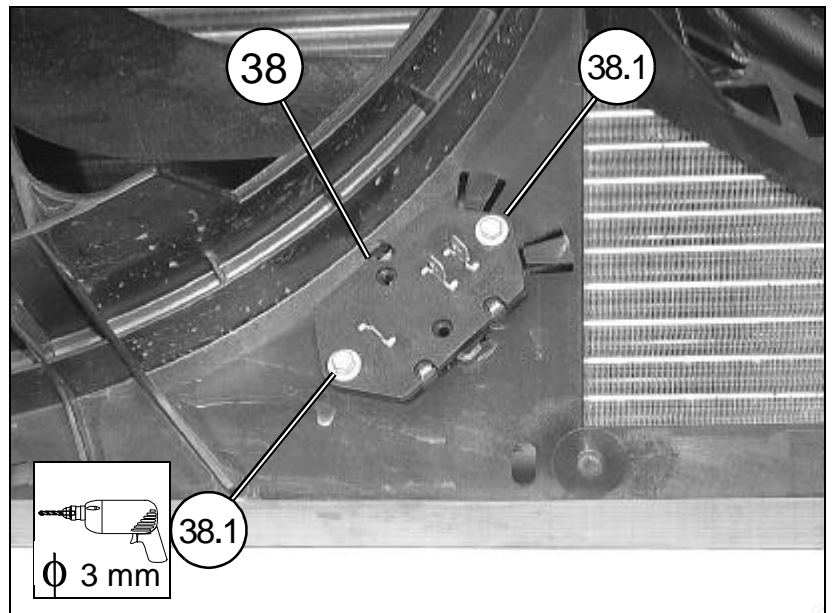
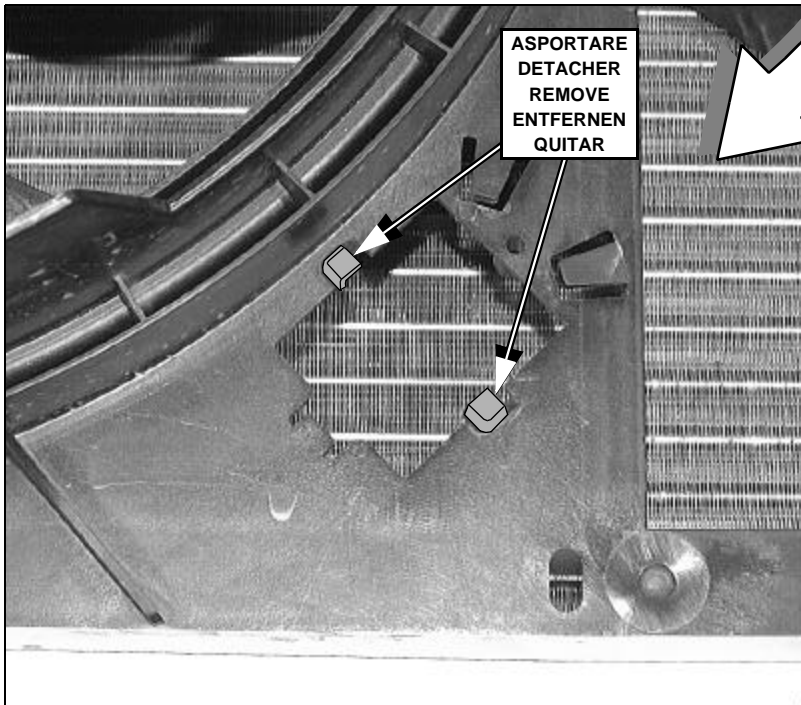

ELEMENTI DI FISSAGGIO PIECES DE FIXATION / FIXING PARTS BEFESTIGUNGSELEMENTE ELEMENTOS DE FIJACION		
Pos.	Tipologia Typologie Typology Tipologie Tipologia	Descrizione Description Description Beschreibung Descripción
38.1		4,2x16

9B

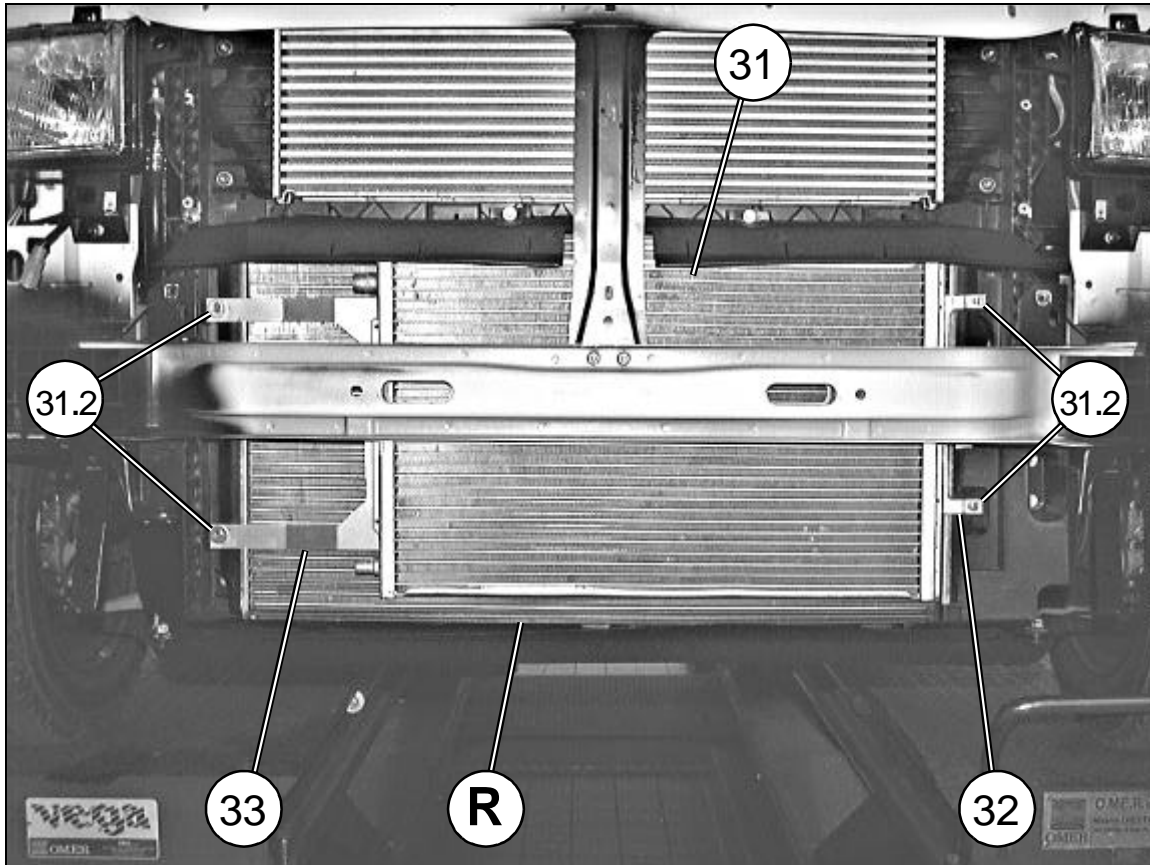

ELEMENTI DI FISSAGGIO PIECES DE FIXATION / FIXING PARTS BEFESTIGUNGSELEMENTE ELEMENTOS DE FIJACION		
Pos.	Tipologia Typologie Typology Tipologie Tipologia	Descrizione Description Description Beschreibung Descripción
31.2		4,8x13

**MONTAGGIO FILTRO ESSICCATORE / POSE DU FILTRE DESHYDRATEUR / RECEIVER DRIER ASSEMBLY
TROCKNERFILTER EINBAU / MONTAJE DEL FILTRO SECADOR**

MATERIALE FORNITO / MATERIEL FOURNI / SUPPLIED MATERIAL / GELIEFERTES MATERIAL / MATERIAL ABASTECIDO

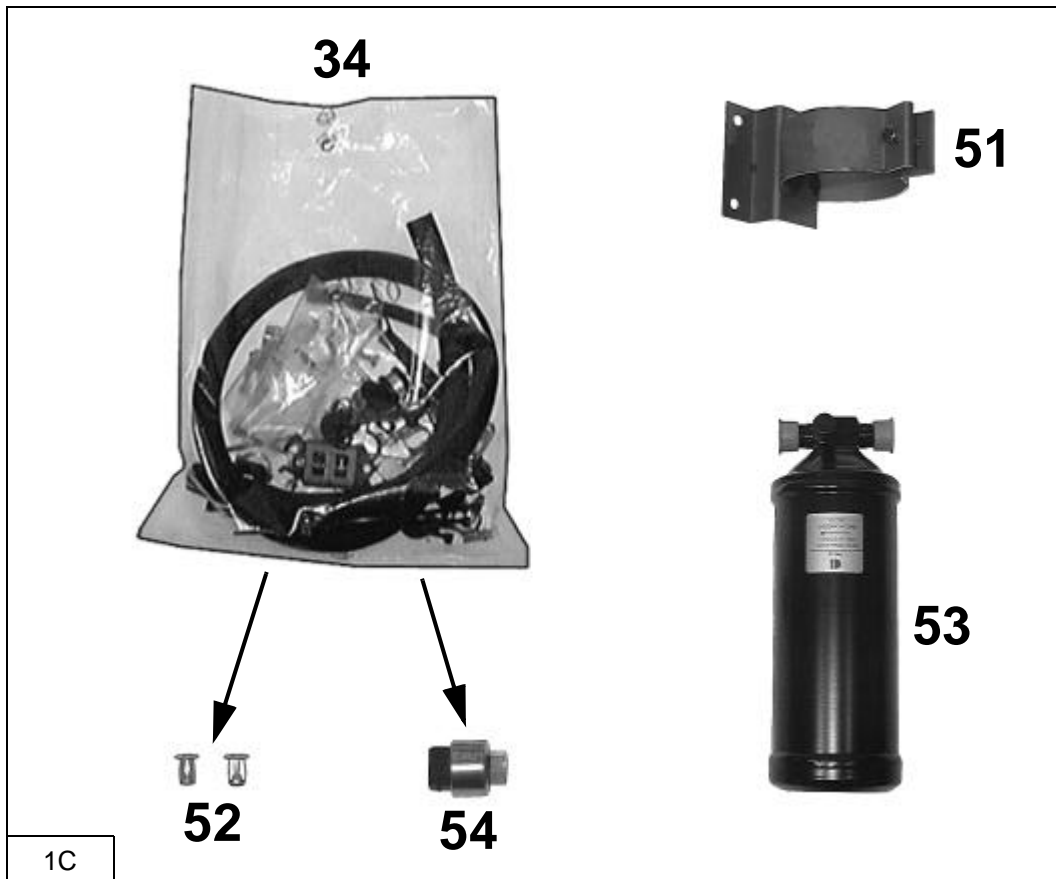

1C

Pos.	Descrizione / Description / Description Beschreibung / Descripción	Codice / Code Kode / Código
34	Sacchetto accessori	0231663/0
51	Staffa filtro	0361759/0
52	Inserto filettato M6	062089/0
53	Filtro essiccatore	017050/0
54	Pressostato	043118/1

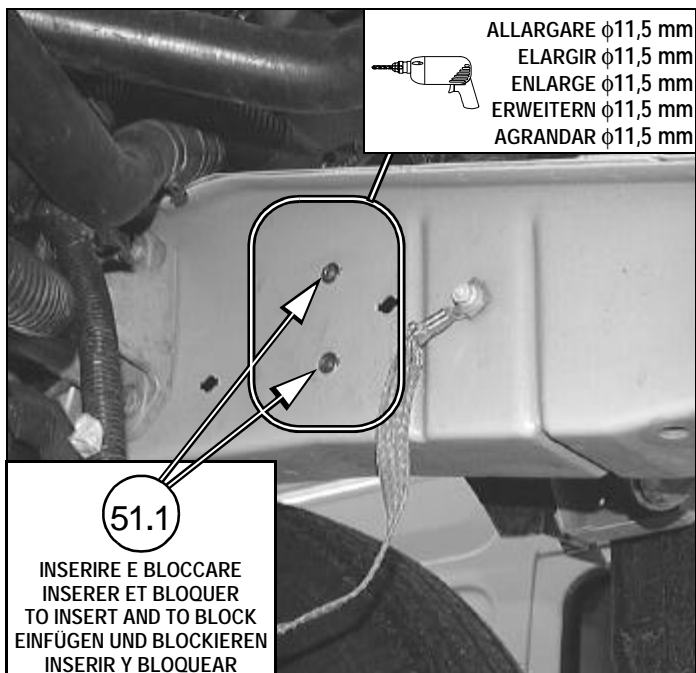

2C

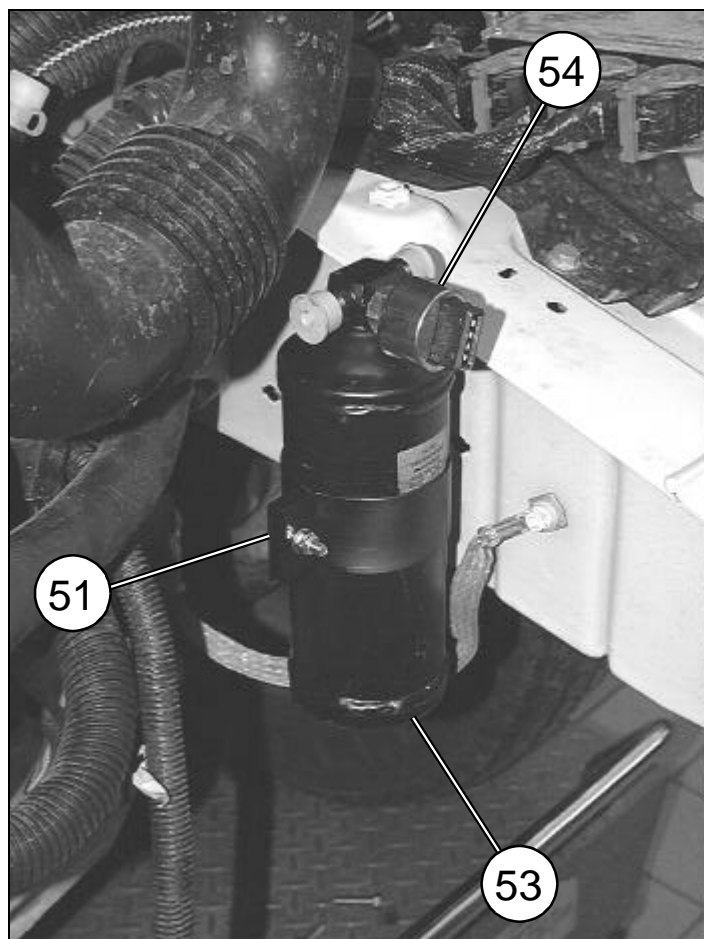
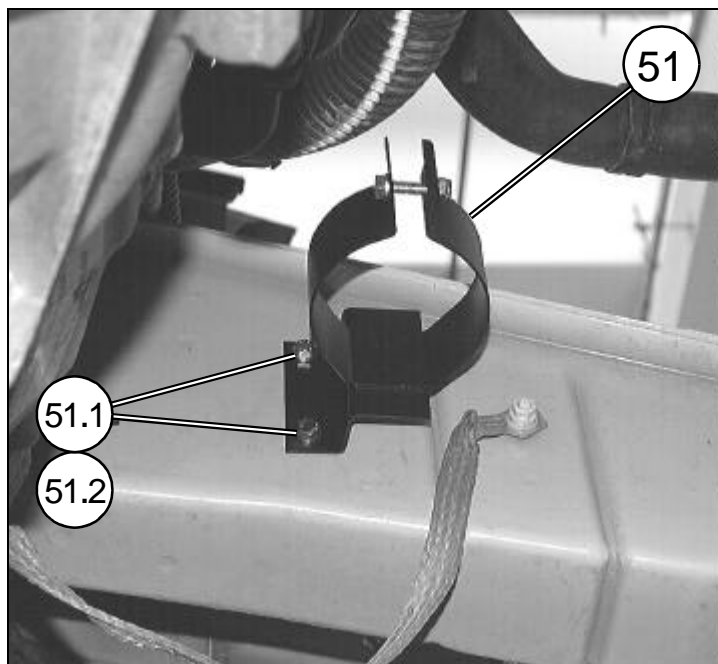

ELEMENTI DI FISSAGGIO / PIÈCES DE FIXATION FIXING PARTS / BEFESTIGUNGSELEMENTE ELEMENTOS DE FIJACION		
Pos.	Tipologia / Typologie Typology / Tipologie Tipologia	Descrizione / Description Description / Beschreibung Descripción
51.1		M6x20
51.2		ø 6

MONTAGGIO COMPONENTI A.C. NELL'ABITACOLO (parte evaporante-comandi)
POSE DES COMPOSANTS A.C. DANS L'HABITACLE (évaporateur-commandes)
A.C. COMPONENTS ASSEMBLY IN THE PASSENGER COMPARTMENT (evaporator-controls)
EINBAU DER KLIMAANLAGEN-BESTANDTEILE IM WAGENINNEREN (Seite der Verdampfersteuerung)
MONTAJE COMPONENTES A.C. EN EL HABITACULO (parte evaporador-mandos)

MATERIALE FORNITO / MATERIEL FOURNI / SUPPLIED MATERIAL / GELIEFERTES MATERIAL / MATERIAL ABASTECIDO

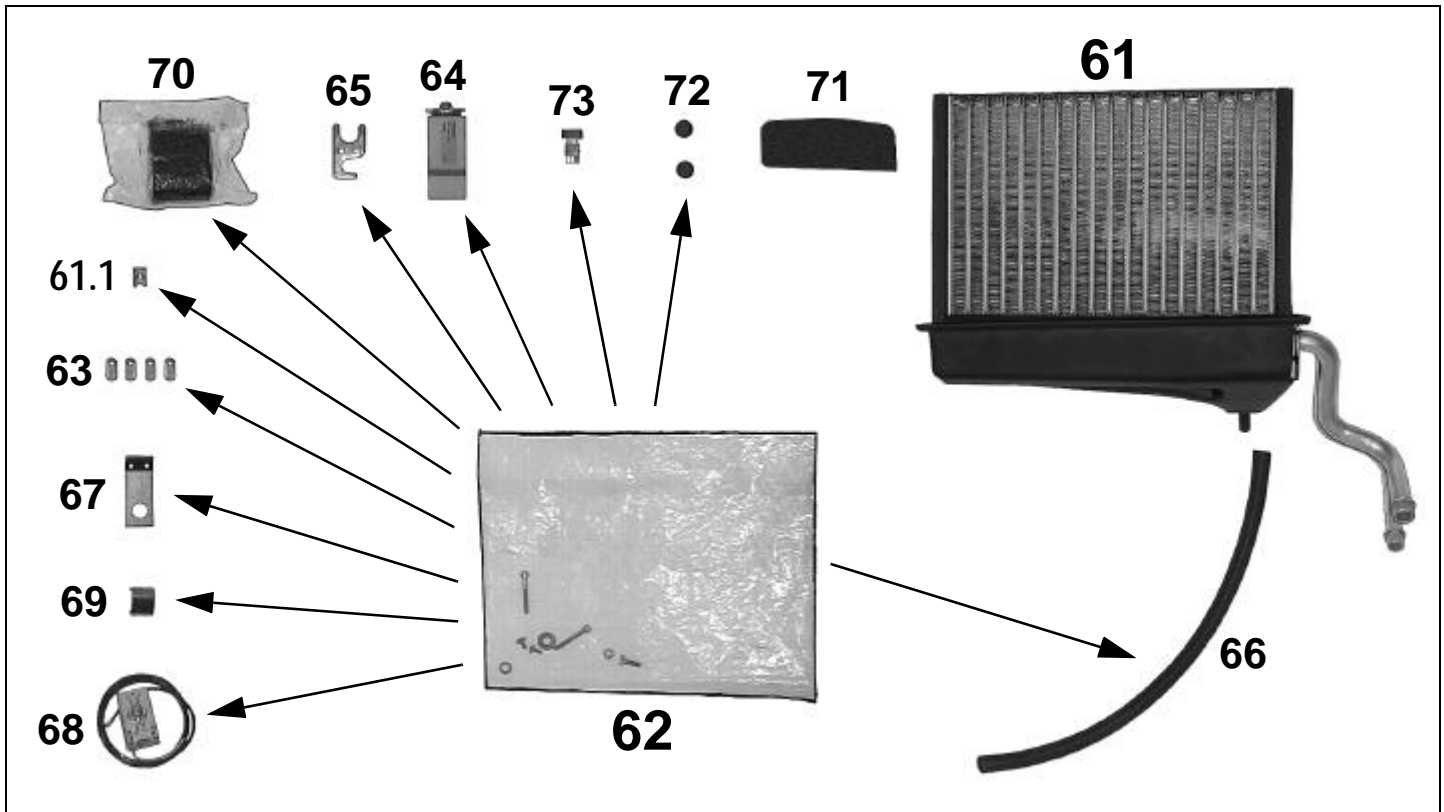

1D

Pos.	Descrizione / Description Description / Beschreibung Descripción	Codice / Code Kode / Código
61	Batteria evaporante	0301079/0
61.1	Graffetta a molla per vite autofilettante	062079/0
62	Sacchetto accessori	029854/0
63	Staffa fissaggio batteria evaporante	0682625/0
64	Valvola di espansione	058041/0
65	Flangia fissaggio valvola	043060/0
66	Tubo scarico condensa	069006/0

Pos.	Descrizione / Description Description / Beschreibung Descripción	Codice / Code Kode / Código
67	Staffa supporto termostato	068146/0
68	Termostato	068012/1
69	Molla fissaggio bulbo	069180/0
70	Mastice anticondensa	070001/0
71	Porta-interruttore	0321933/0
72	Copriforo	069049/0
73	Interruttore di comando A.C.	068540.3

MATERIALE FORNITO / MATERIEL FOURNI / SUPPLIED MATERIAL / GELIEFERTES MATERIAL / MATERIAL ABASTECIDO

1.1D

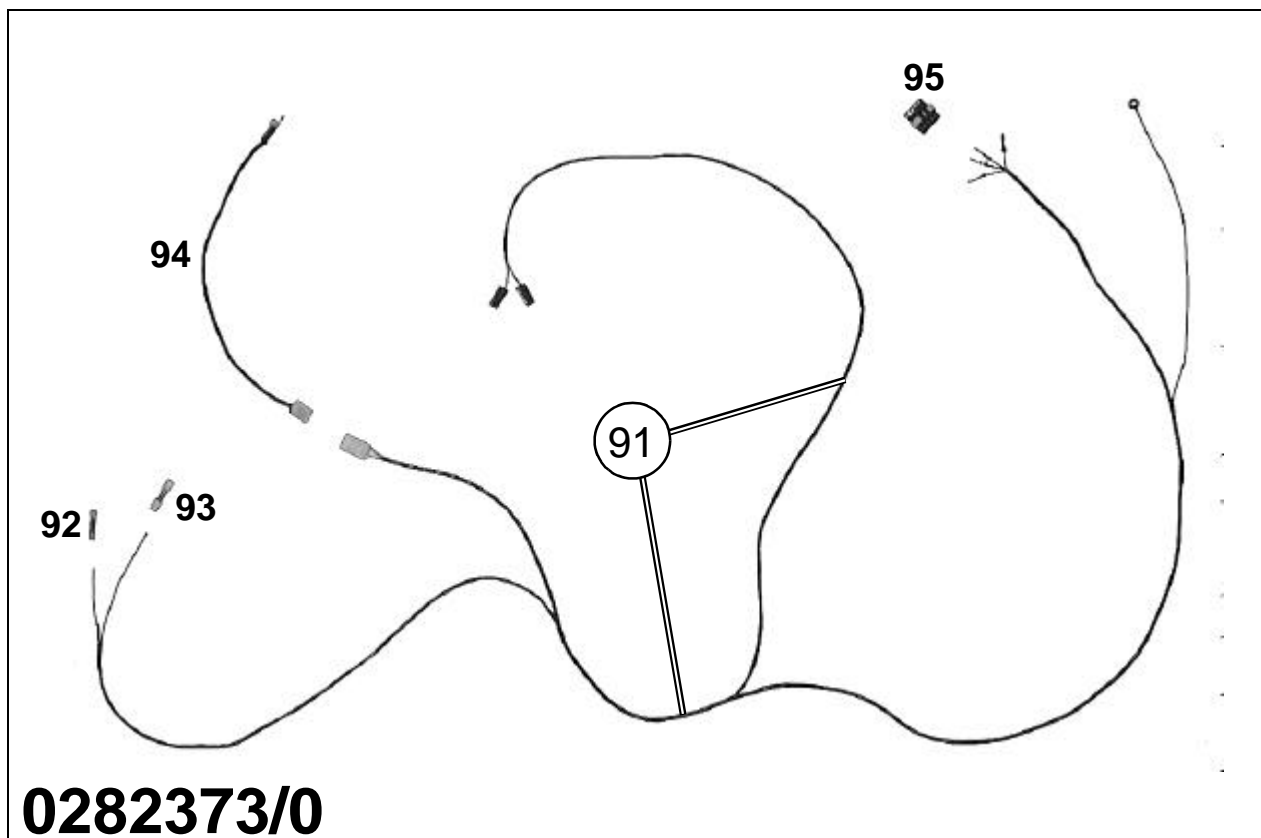

Pos.	Descrizione / Description Description / Beschreibung Descripción	Codice / Code Kode / Código
91	Impianto elettrico comandi	0282373/0
92	Giunzione RAYCHEM BLU	064273/0
93	Giunzione RAYCHEM GIALLA	064272/0
94	Circuito illuminazione	0681649/1
95	Connettore 5 vie	-

OPERAZIONI PRELIMINARI / OPERATIONS PRELIMINAIRES / PRELIMINARY OPERATIONS
VORBEREITUNGSARBEITEN / OPERACIONES PRELIMINARES

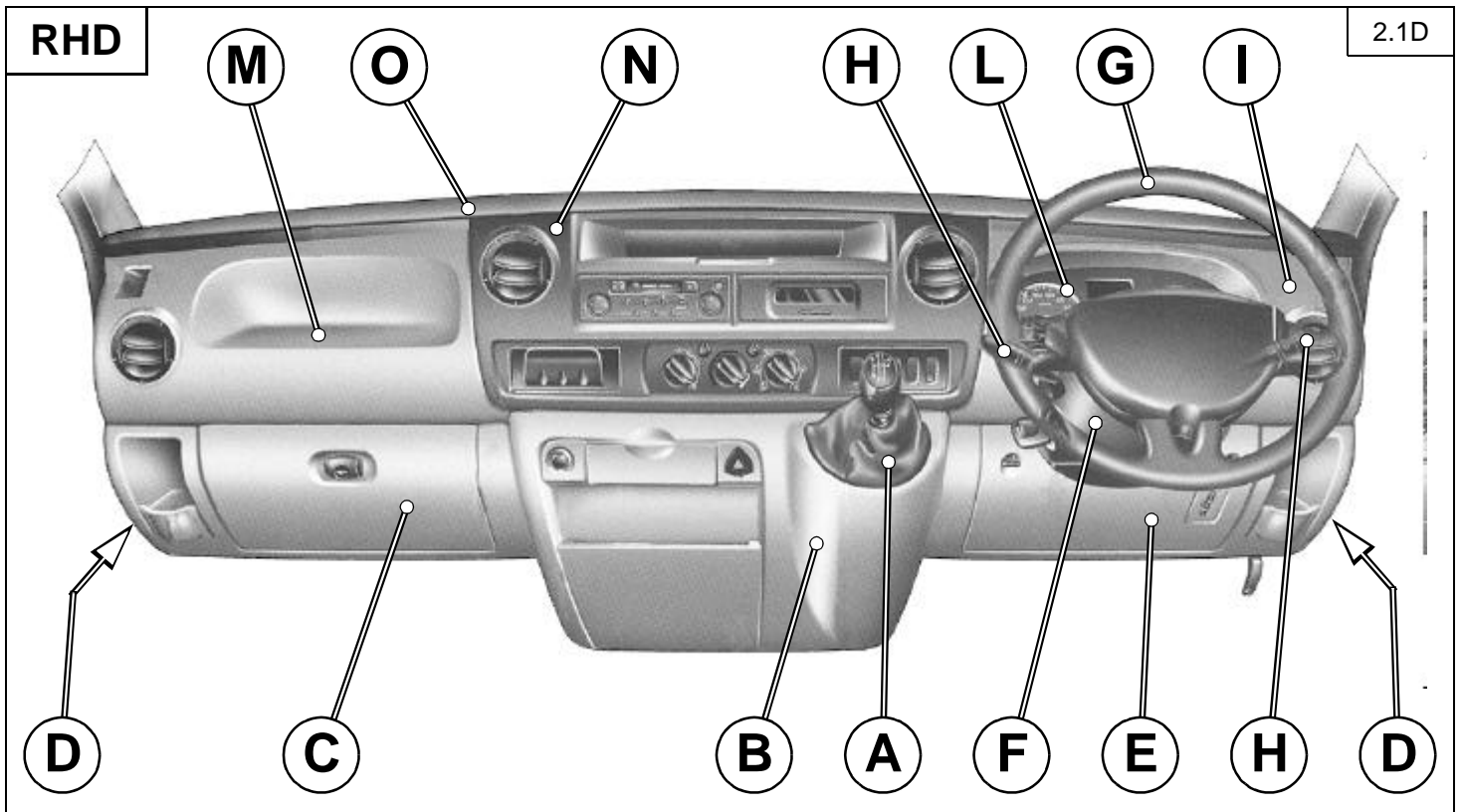
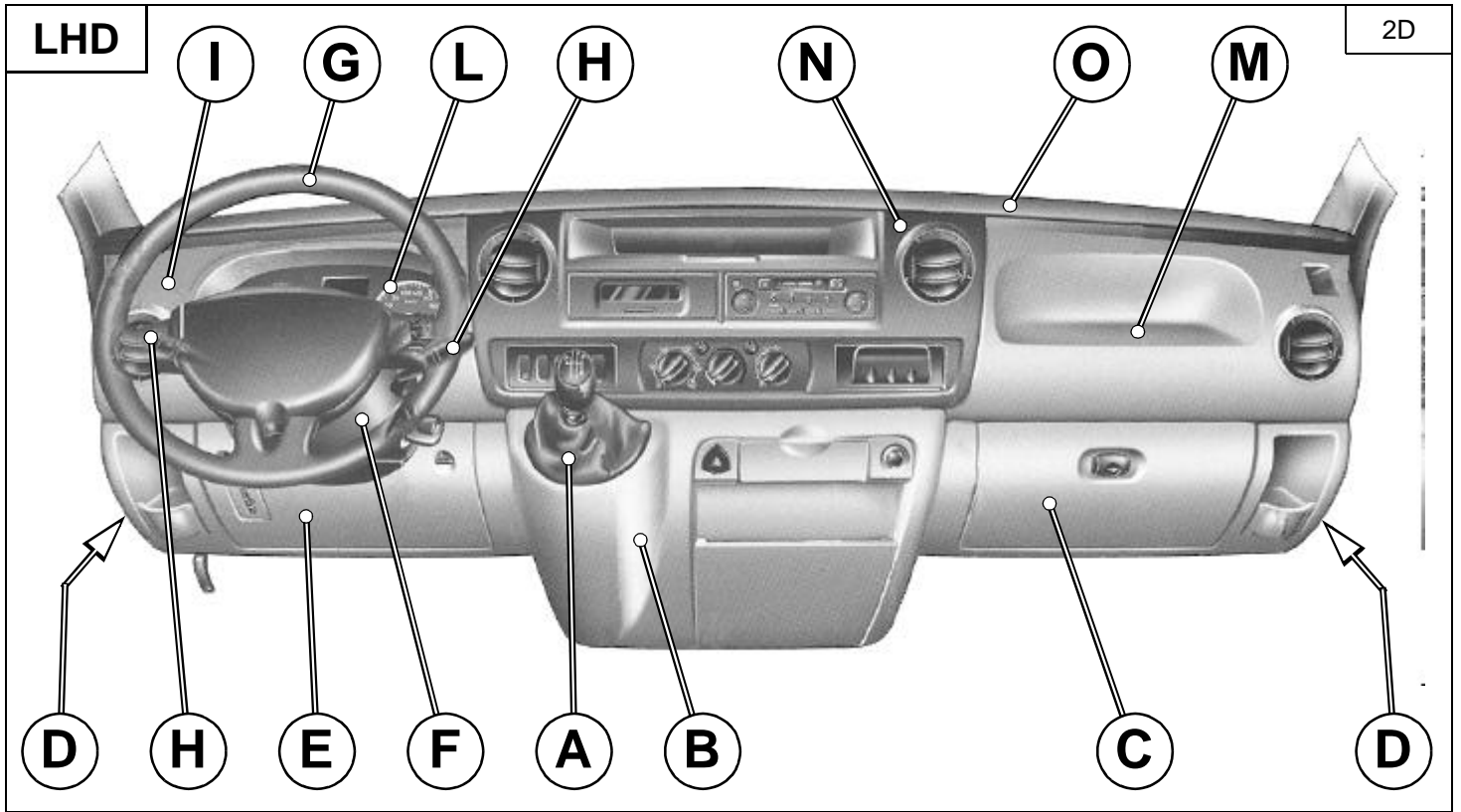

(I)

SMONTARE NELL'ABITACOLO:

A) Cuffia leva cambio; **B)** Tunnel centrale della leva cambio; **C)** Cassetto porta-oggetti; **D)** Fianchetti laterali del cruscotto; **E)** Pannello sottopancia lato guida; **F)** Copripiantone inferiore e superiore dello sterzo; **G)** AIR-BAG e volante (mantenere diritto il volante e bloccare l'anello di connessione con nastro adesivo); **H)** Gruppo leveraggi di comando luci e tergicristalli; **I)** Cornice quadro strumentazione; **L)** Quadro strumentazione; **M)** Vano porta-oggetti; **N)** Consolle centrale completa di autoradio, orologio ed interruttori di servizio; **O)** Cruscotto scollegando tutti i collegamenti elettrici; **P)** Barra trasversale, rimuovendo i fissaggi del piantone sterzo; **Q)** Gruppo riscaldamento, scollegando i relativi tubi acqua.

(F)

DEPOSER DANS L'HABITACLE :

A) Protection pour levier de changement de vitesse; **B)** Tunnel central du levier de changement de vitesse; **C)** Boîte à gants; **D)** Éléments latéraux tableau de bord; **E)** Panneau sous le tableau de bord côté conduite; **F)** Couvre-colonne de direction inférieur et supérieur; **G)** AIR-BAG et volant (maintenir le volant droit et fixer l'anneau de connexion à l'aide de ruban adhésif); **H)** Groupe leviers de commandes feux et essuie-glaces; **I)** Cadre tableau de bord; **L)** Tableau de bord; **M)** Compartiment vide-poche; **N)** Console central avec autoradio, horloge et interrupteurs de service; **O)** Tableau de bord en déconnectant tous les branchements électriques; **P)** Barre transversale en éliminant les pièces de fixation colonne de direction; **Q)** Groupe chauffage en déconnectant les tuyaux de l'eau.

(GB)

REMOVE IN THE PASSENGER COMPARTMENT :

A) Gear lever guard; **B)** Central shift stick; **C)** Glove compartment; **D)** Dashboard side piece; **E)** Panel under the dashboard on driver's side; **F)** Upper and lower steering column casing; **G)** AIR-BAG and steering wheel (keep the steering wheel straight and tape down the connection ring); **H)** Light and windshield wiper control lever assembly; **I)** Instrument panel frame; **L)** Instrument panel; **M)** Glove compartment; **N)** Central console including radio, clock and service switch; **O)** Dashboard disconnecting all electrical wires; **P)** Transverse bar by removing the steering wheel column fasteners; **Q)** Heating unit by disconnecting the water pipes.

(D)

VOM FAHRZEUGINNEREN AUSZUBAUEN:

A) Ganghebelabdeckung; **B)** Konsole des Getriebehebels; **C)** Handschuhkasten; **D)** Seitenwand des Armaturenbretts; **E)** Abdeckung unter dem Armaturenbrett - Fahrerseite; **F)** Untere und obere Lenksäulenabdeckung des Lenkrads; **G)** AIR-BAG und Lenkrad (Das Lenkrad gerade halten und den Verbindungsring mit Klebeband blockieren); **H)** Bedienungshebel Licht und Scheibenwischer; **I)** Instrumententafelrahmen; **L)** Instrumententafel; **M)** Handschuhkastens; **N)** Mittelkonsole mit Autoradio, Uhr und Bedienungsschaltern; **O)** Armaturenbrett-alle elektrischen Teile abklemmen; **P)** Querträger, indem die Befestigungen der Lenksäule gelöst werden; **Q)** Heizungsgruppe, indem vorher die dazugehörigen Wasserschläuche gelöst werden.

(E)

DESMONTAR EL EN HABITÁCULO:

A) Funda palanca de cambio; **B)** Túnel central de la palanca de velocidades; **C)** Guanterera; **D)** Elementos laterales del tablero; **E)** Panel bajo placa lado del conductor; **F)** Cubre columna inferior y superior del volante; **G)** AIR-BAG y volante (tener el volante en posición recta y bloquear el anillo de conexión con tira adhesiva); **H)** Grupo del mecanismo de palancas de mando luces y limpiaparabrisas; **I)** Marco tablero de instrumentos; **L)** Tablero de instrumentos; **M)** Espacio guanterera; **N)** Consola central con radio de coche, reloj e interruptores de servicio incluidos; **O)** Tablero desconectando todas las conexiones eléctricas; **P)** Barra transversal, eliminado las fijaciones de la columna de la dirección; **Q)** Grupo de calefacción, desconectando los relativos tubos del agua.

LHD

ORIGINALE
ORIGINAL

SMONTARE
DEMONTER
REMOVE
AUSBAUEN
DESMONTAR



SEPARARE
SÉPARER
SEPARATE
TRENNEN
SEPARAR

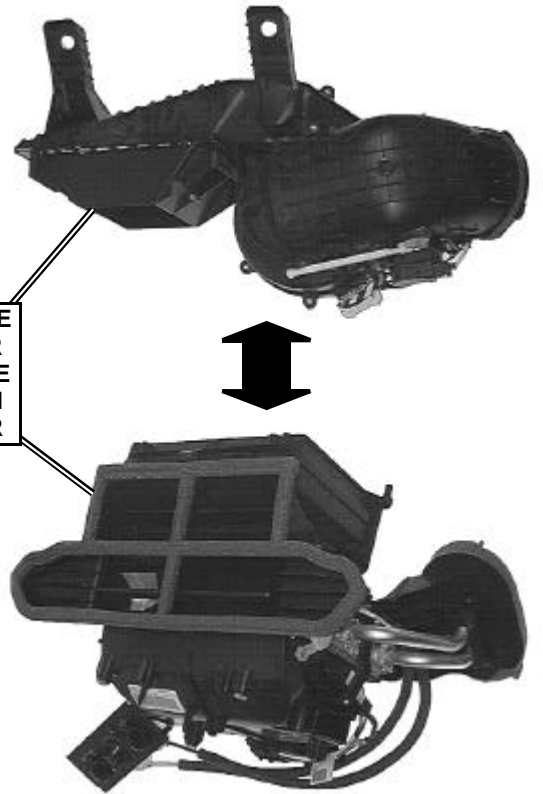

3D

RHD

ORIGINALE
ORIGINAL

SMONTARE
DEMONTER
REMOVE
AUSBAUEN
DESMONTAR



SEPARARE
SÉPARER
SEPARATE
TRENNEN
SEPARAR

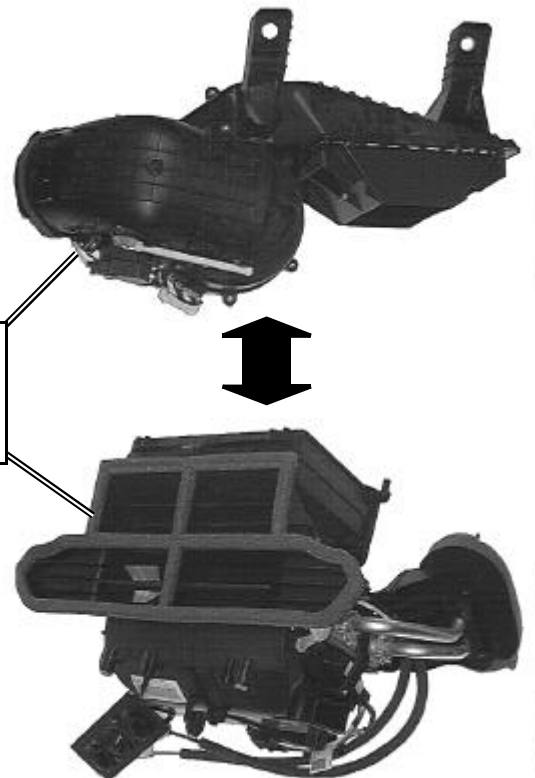

4D

ORIGINALE
ORIGINAL

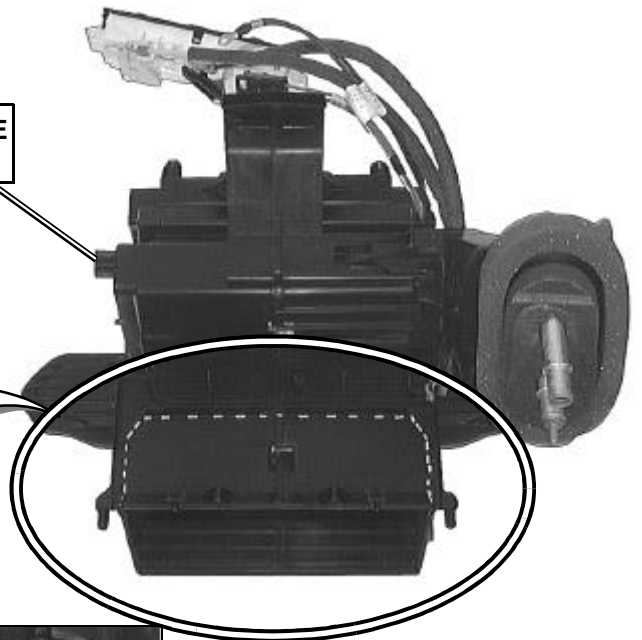

5D

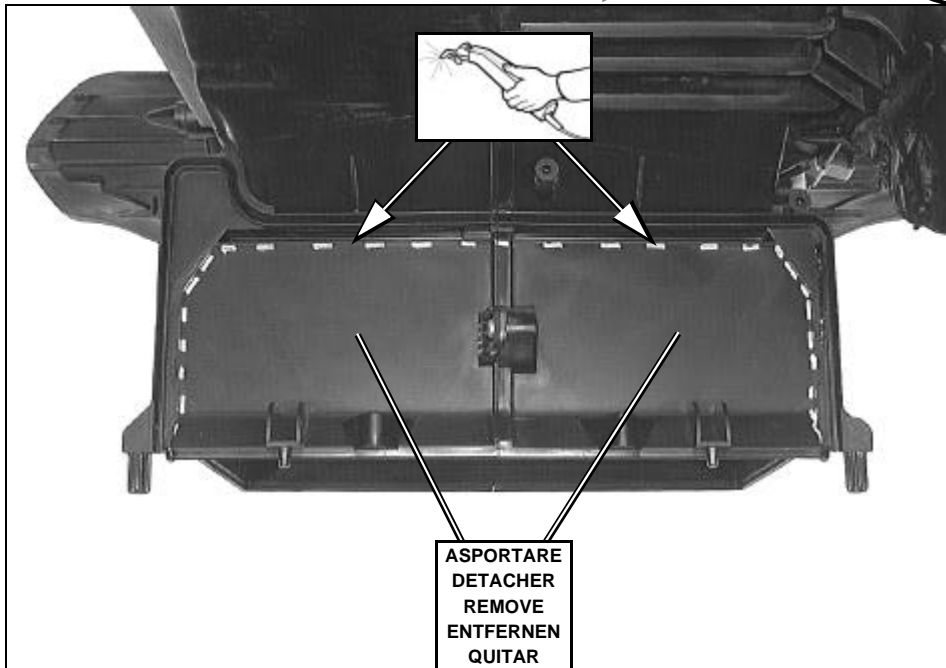

ELIMINARE
ELIMINER
DISCARD
ENTFERNEN
ELIMINAR

CONSERVARE
GARDER
KEEP
AUFBEWAHREN
CONSERVAR



ORIGINALE
ORIGINAL



6D

LHD

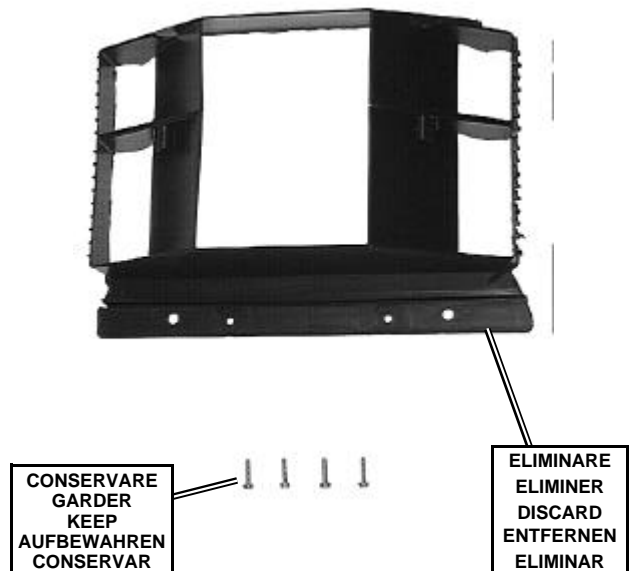
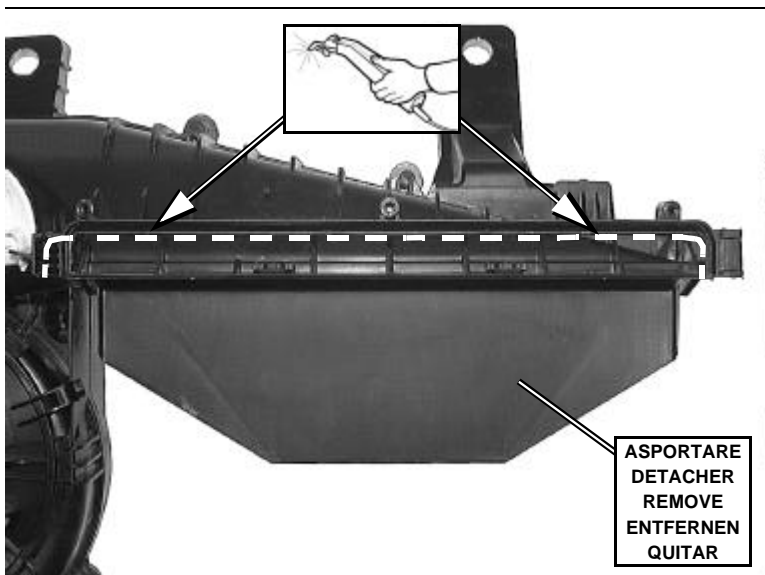
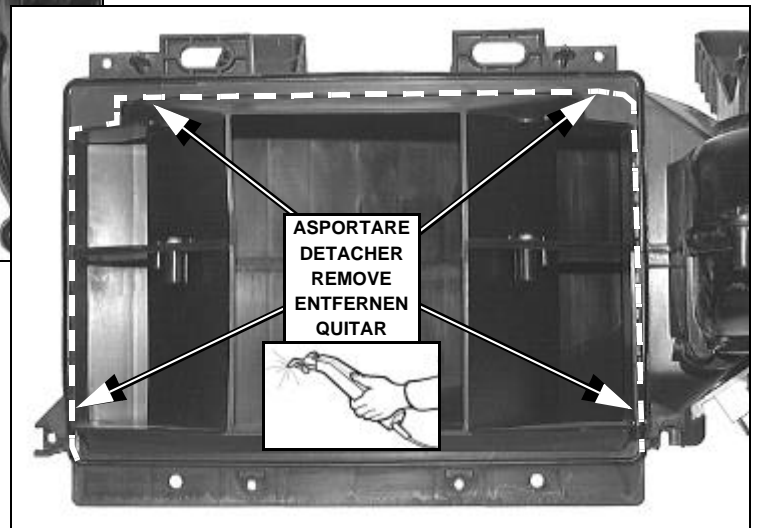
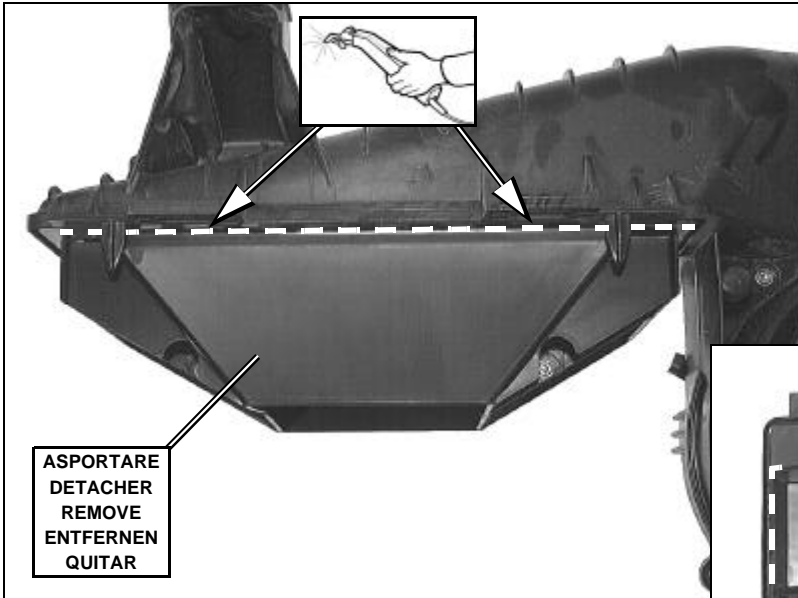

ORIGINALE
ORIGINAL

7D

RHD

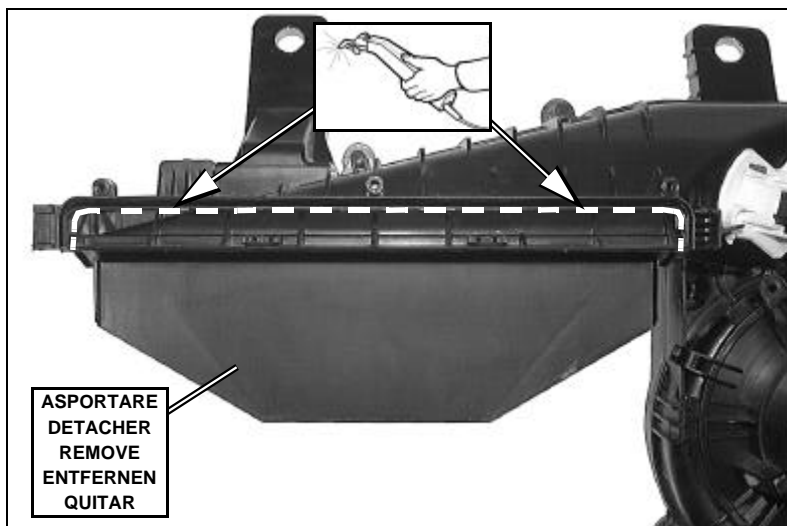
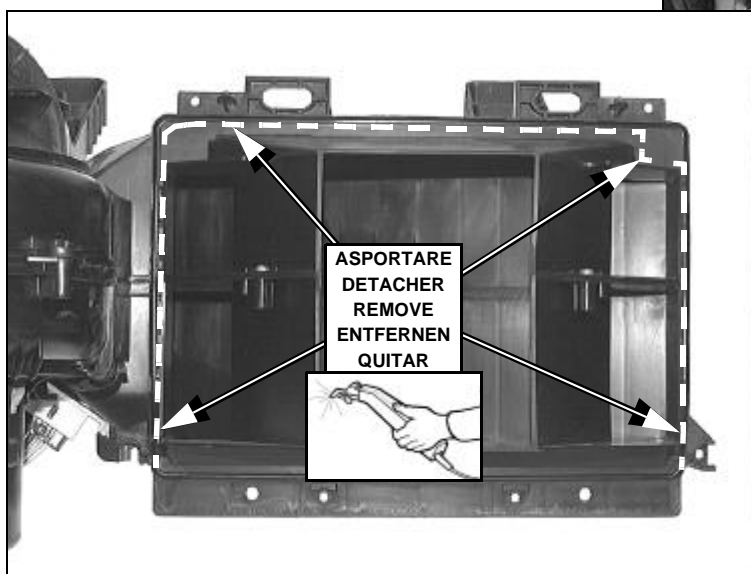
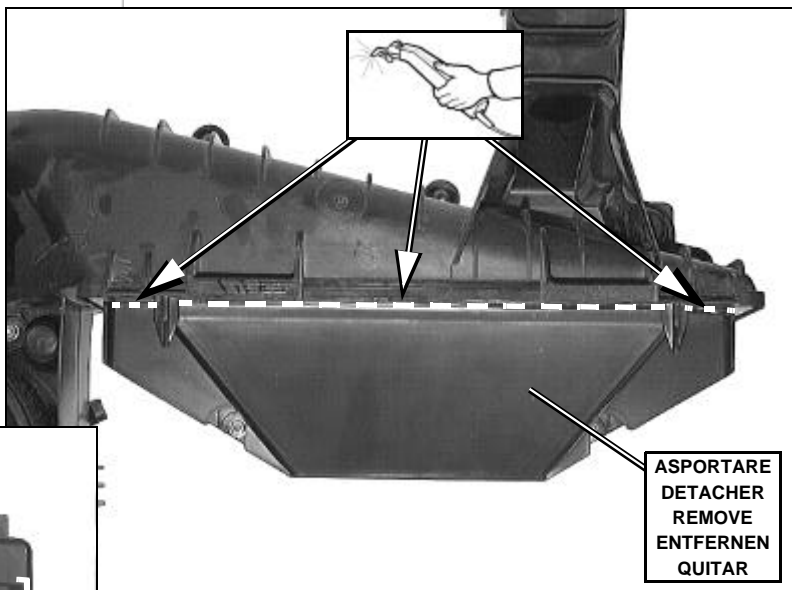

CONSERVARE
GARDER
KEEP
AUFBEWAHREN
CONSERVAR

ELIMINARE
ELIMINER
DISCARD
ENTFERNEN
ELIMINAR

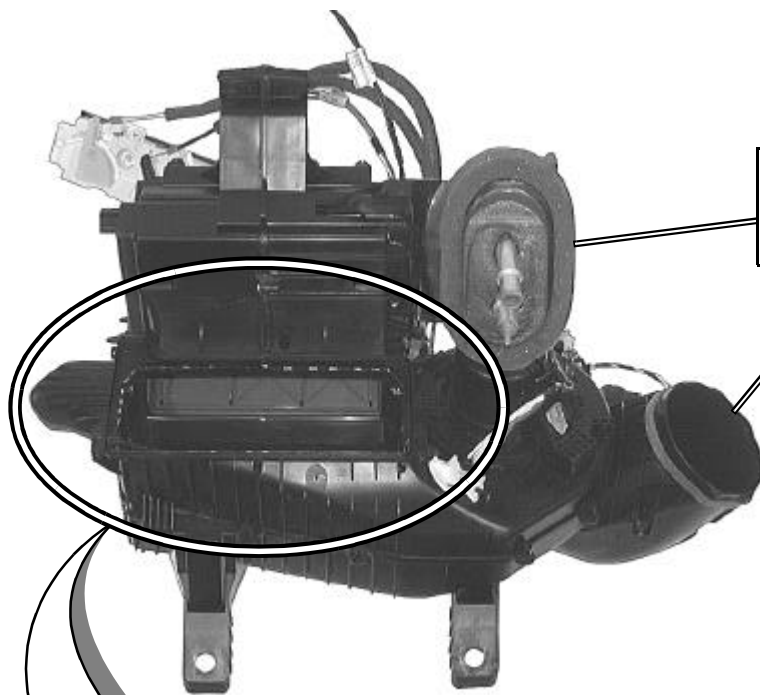

RIASSEMBLARE
RASSEMBLER
REASSEMBLE
WIEDER ZUSAMMENBAUEN
VOLVER A MONTAR

8D

LHD

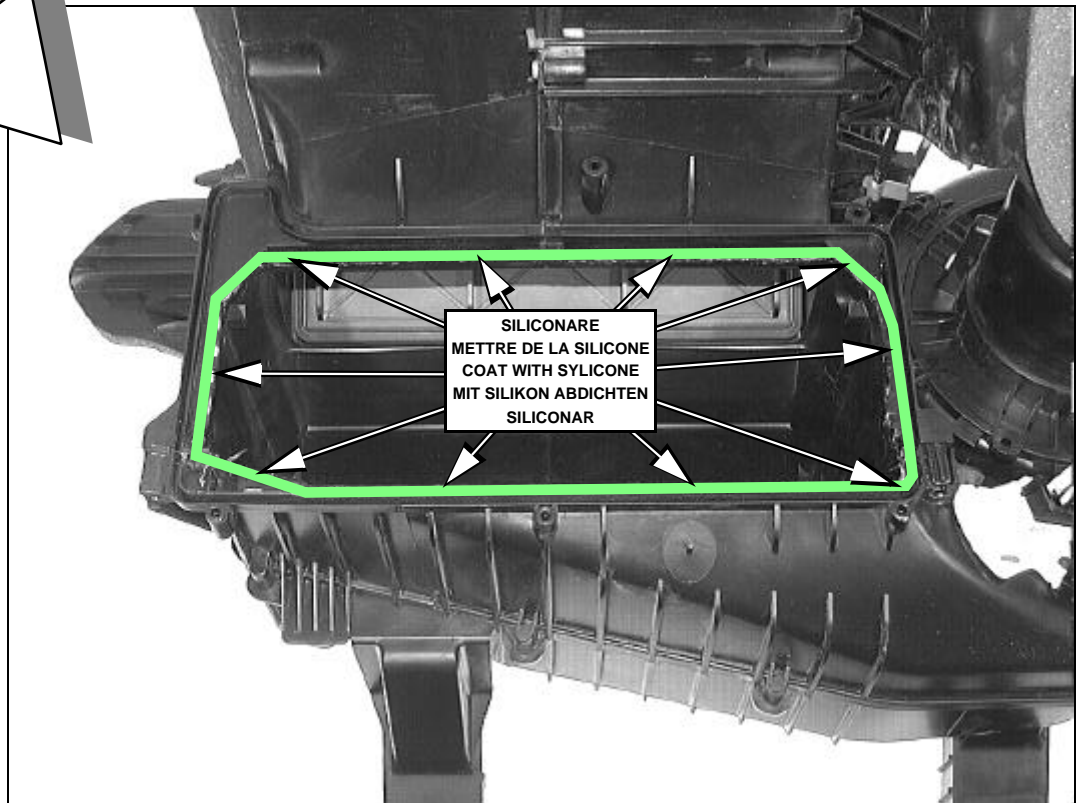
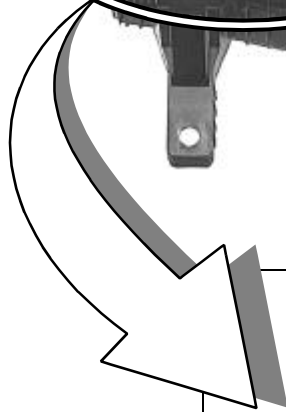

SILICONARE
METTRE DE LA SILICONE
COAT WITH SYLICONE
MIT SILIKON ABDICHTEN
SILICONAR

RIASSEMBLARE
RASSEMBLER
REASSEMBLE
WIEDER ZUSAMMENBAUEN
VOLVER A MONTAR

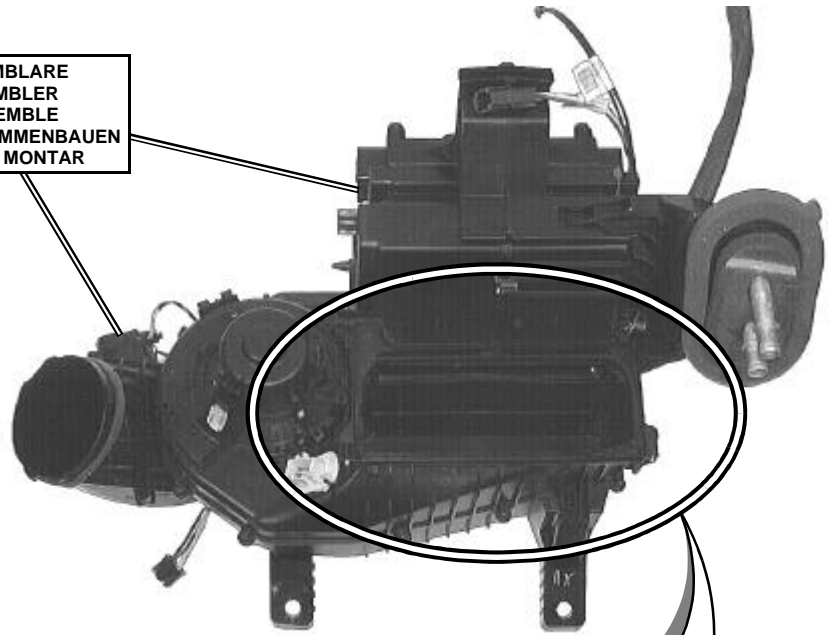

9D

RHD

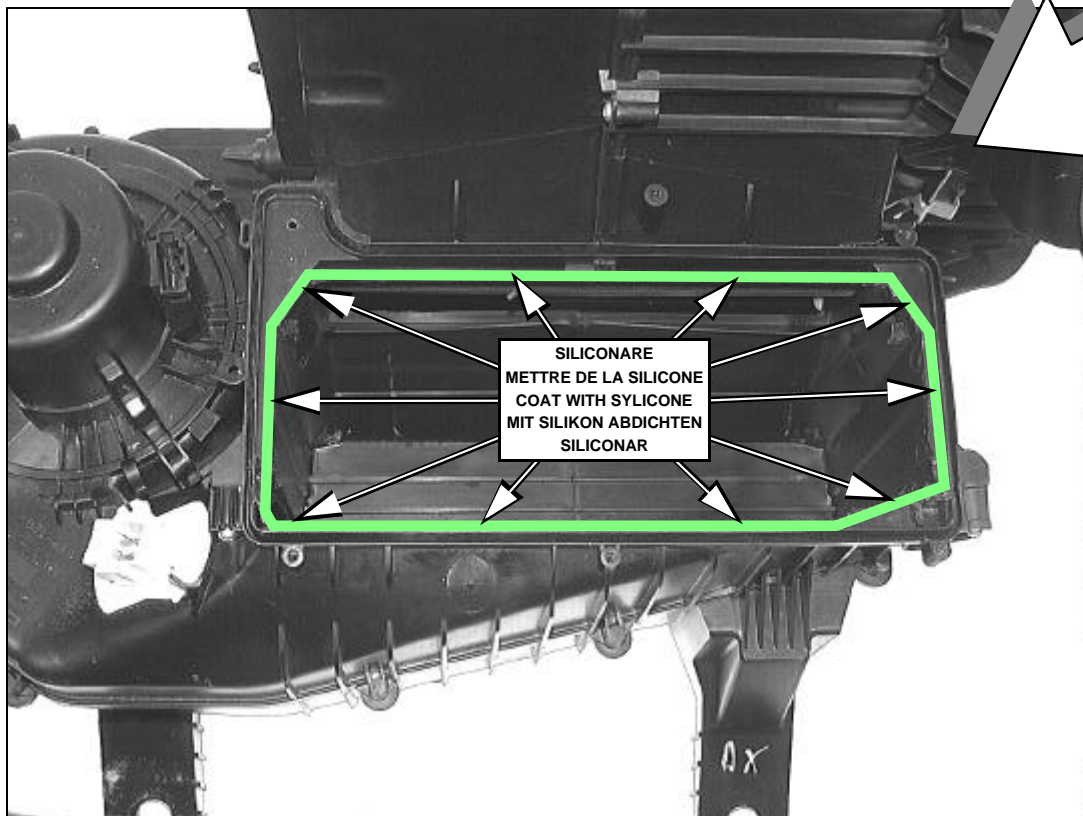

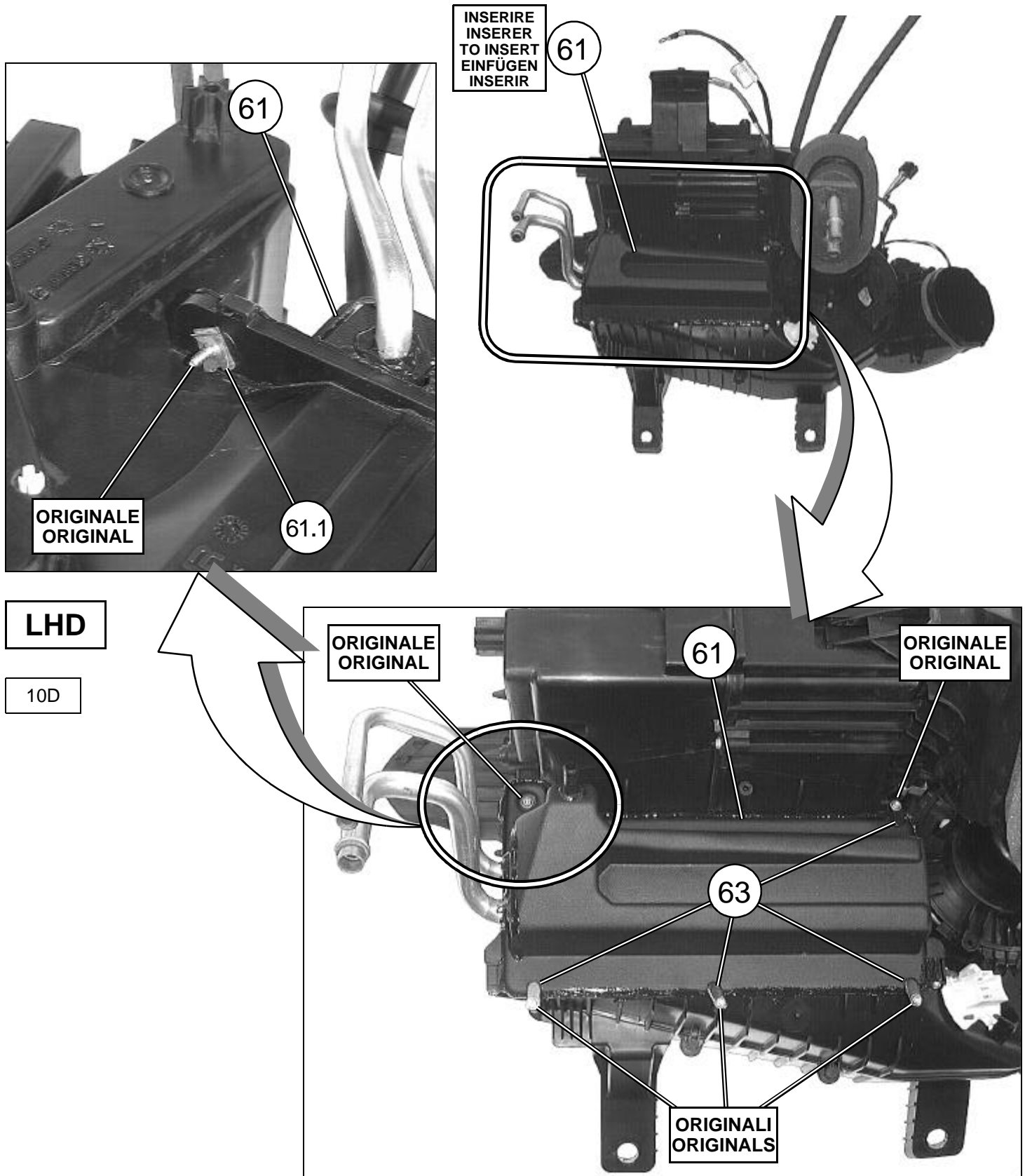

ELEMENTI DI FISSAGGIO / PIECES DE FIXATION / FIXING PARTS / BEFESTIGUNGSELEMENTE / ELEMENTOS DE FIJACION			
Pos.	Tipologia / Typologie / Typology Tipologie / Tipologia	Descrizione / Description / Description Beschreibung / Descripción	Codice / Code Kode / Código
61.1		Graffetta a molla per vite autofilettante	062079/0

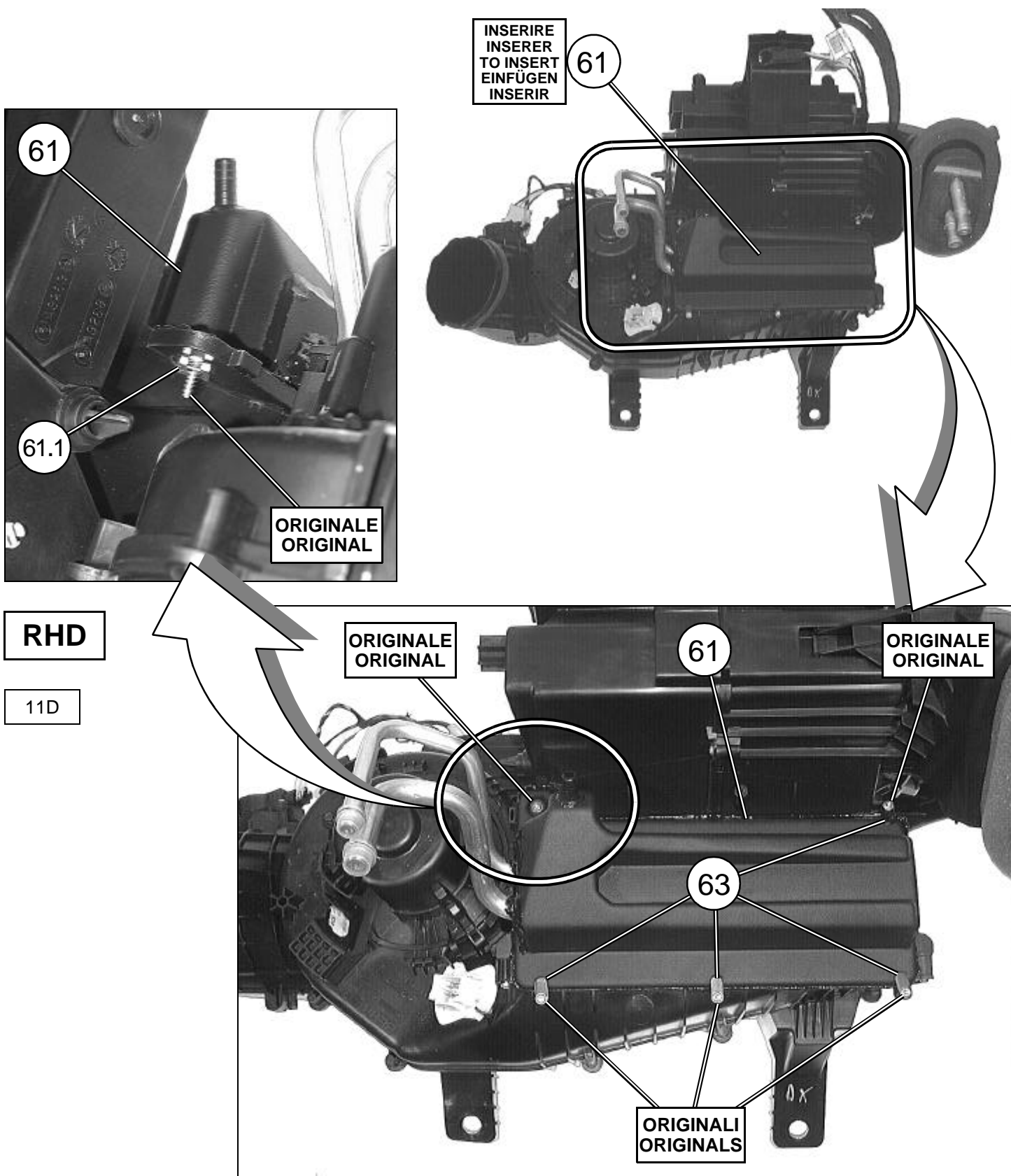

ELEMENTI DI FISSAGGIO / PIECES DE FIXATION / FIXING PARTS / BEFESTIGUNGSELEMENTE / ELEMENTOS DE FIJACION			
Pos.	Tipologia / Typologie / Typology Tipologie / Tipologia	Descrizione / Description / Description Beschreibung / Descripción	Codice / Code Kode / Código
61.1		Graffetta a molla per vite autofilettante	062079/0

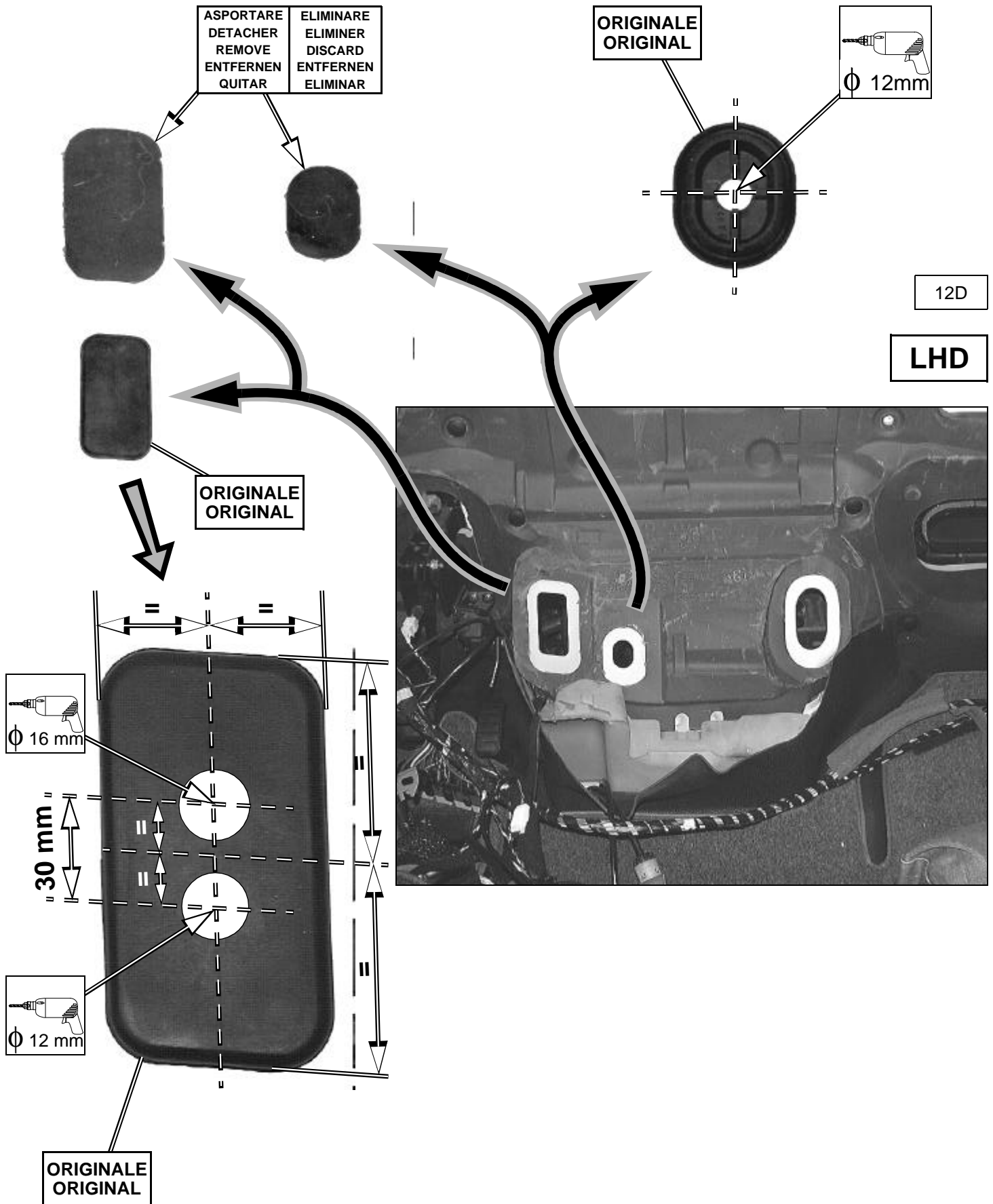

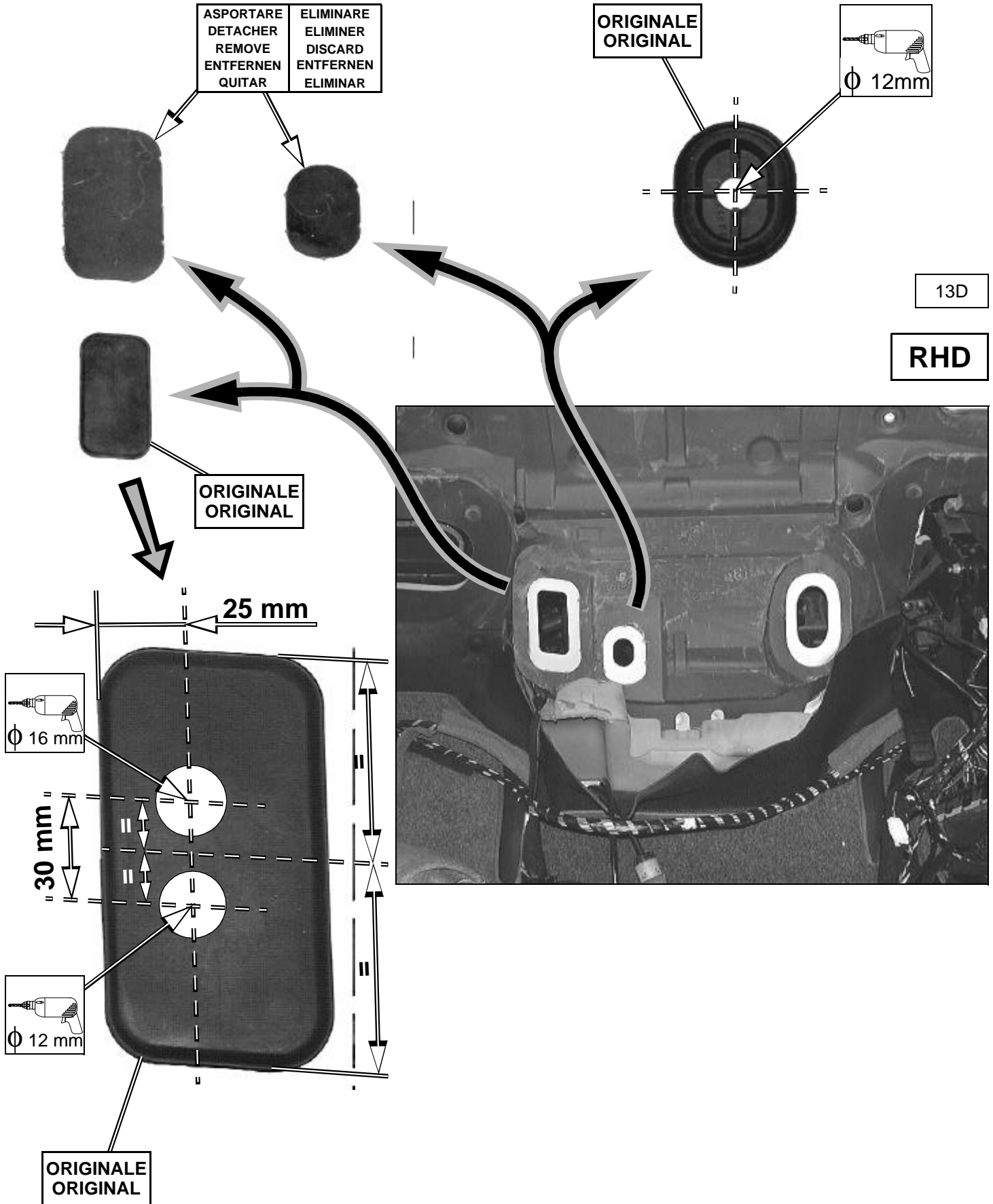

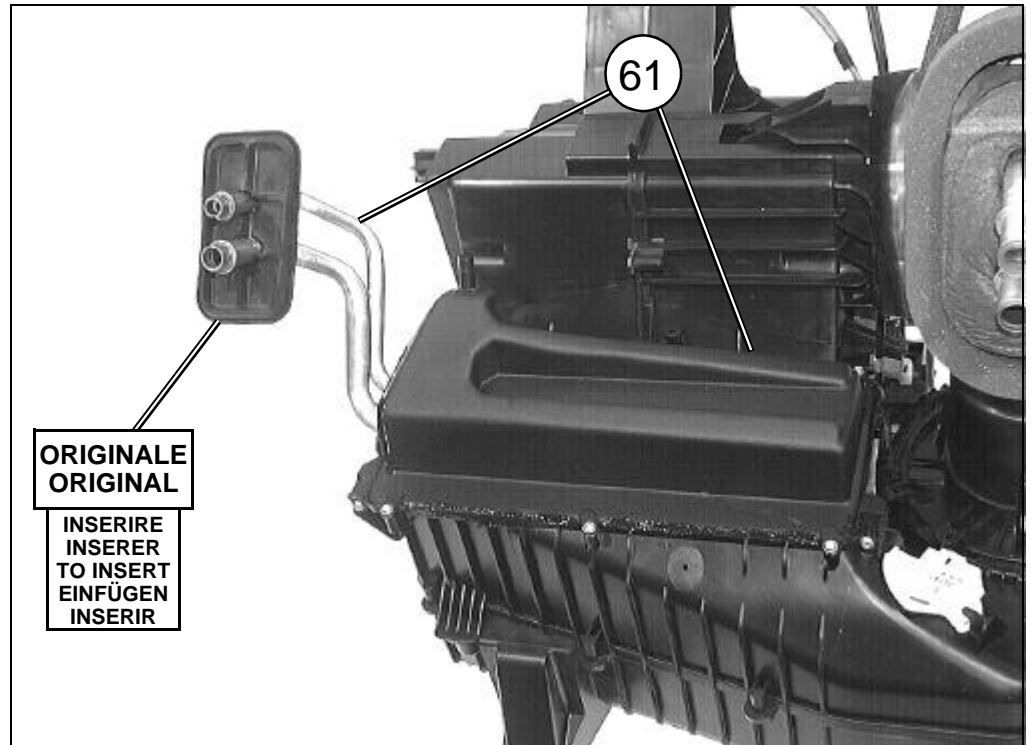

14D

LHD

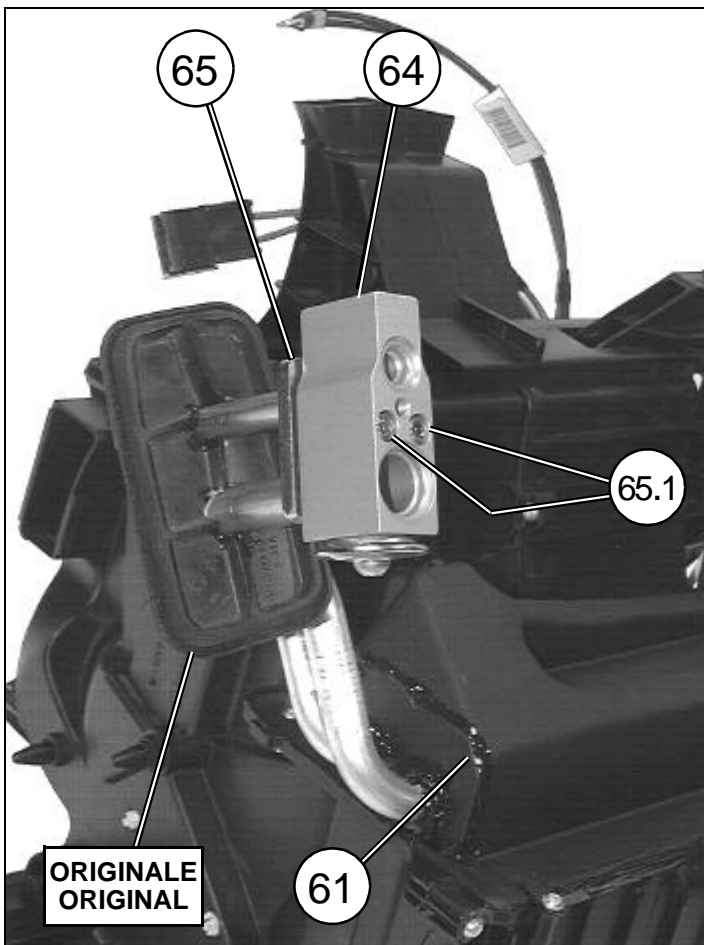

ELEMENTI DI FISSAGGIO / PIECES DE FIXATION FIXING PARTS / BEFESTIGUNGSELEMENTE ELEMENTOS DE FIJACION			
Pos.	Tipologia Typologie Typology Tipologie Tipologia	Descrizione Description Description Beschreibung Descripción	Codice Code Code Codigo
65		Flangia fissaggio valvola	043060/0
65.1		M5x35	-

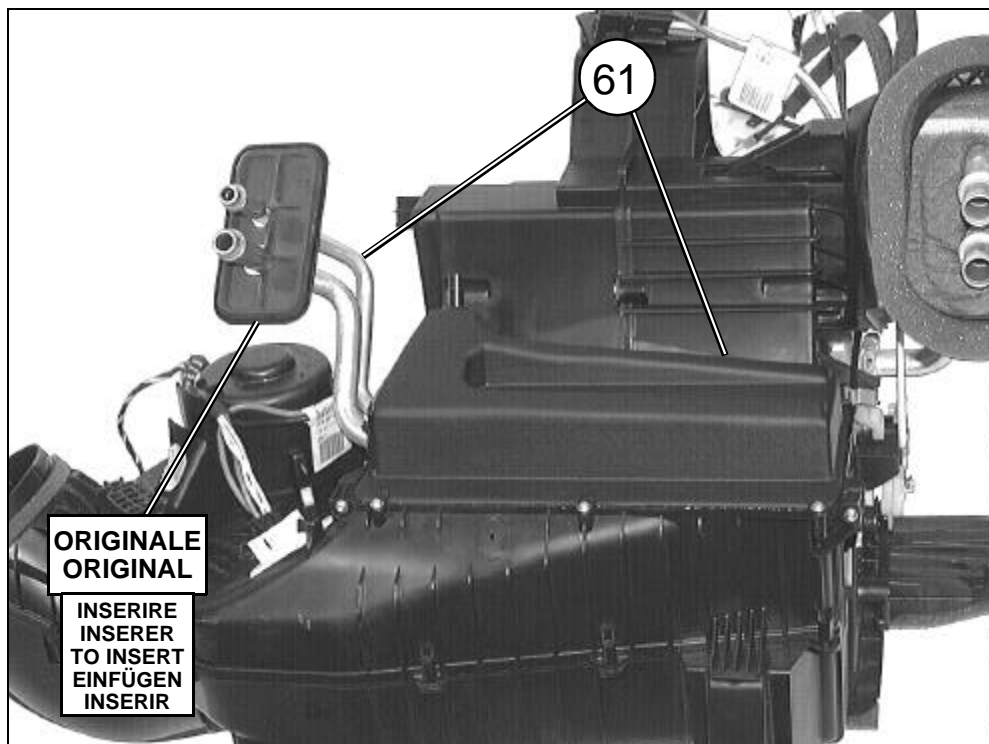

15D

RHD

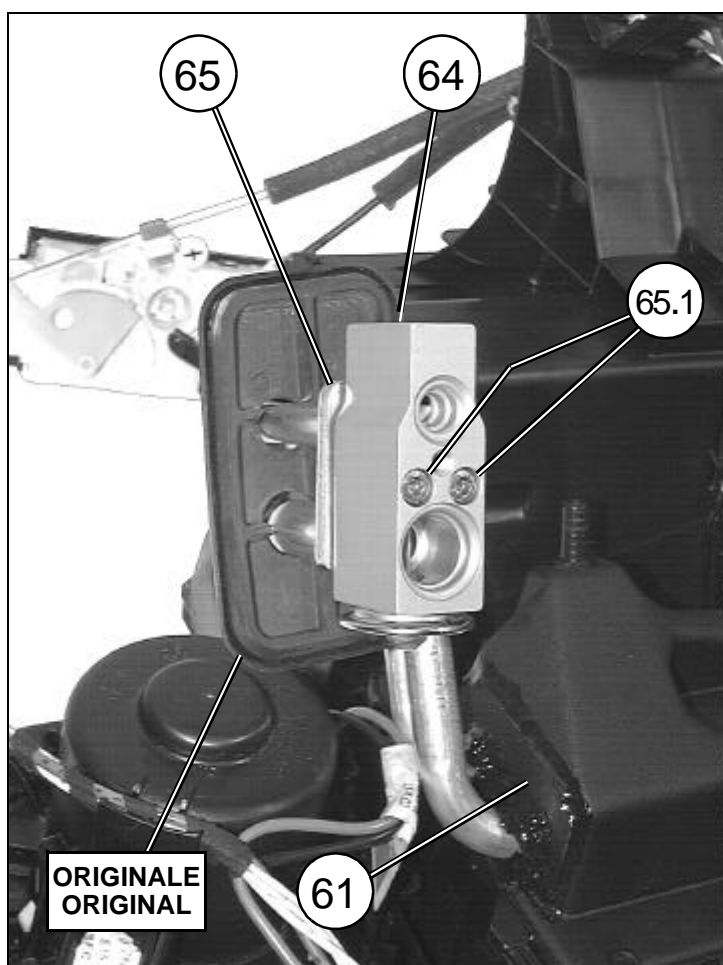

ELEMENTI DI FISSAGGIO / PIECES DE FIXATION FIXING PARTS / BEFESTIGUNGSELEMENTE ELEMENTOS DE FIJACION			
Pos.	Tipologia Typologie Typology Tipologie Tipologia	Descrizione Description Description Beschreibung Descripción	Codice Code Kode Codigo
65		Flangia fissaggio valvola	043060/0
65.1		M5x35	-

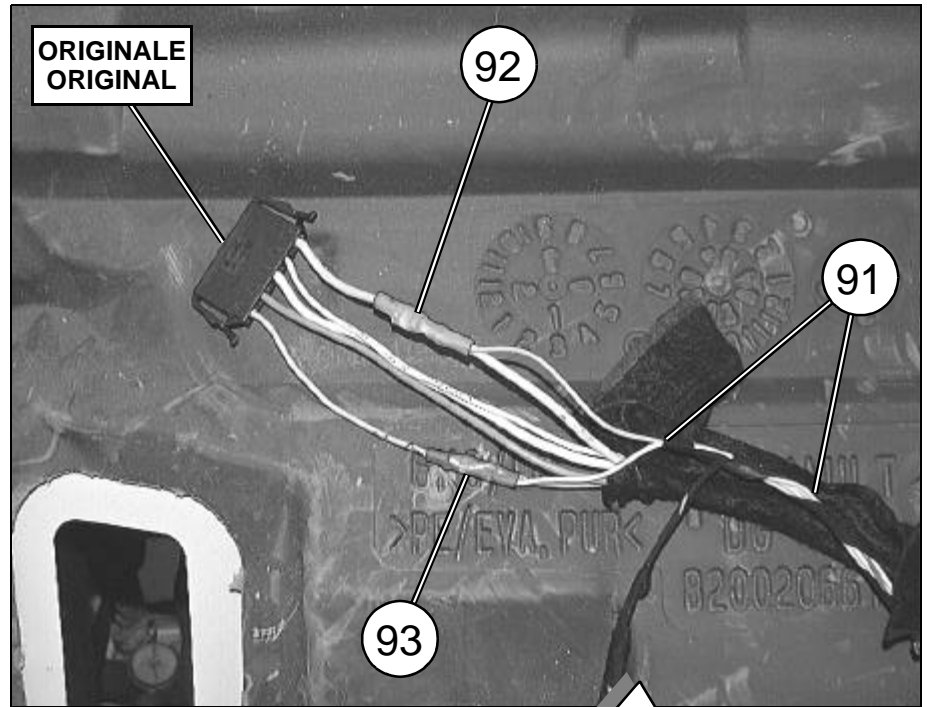

16D

LHD

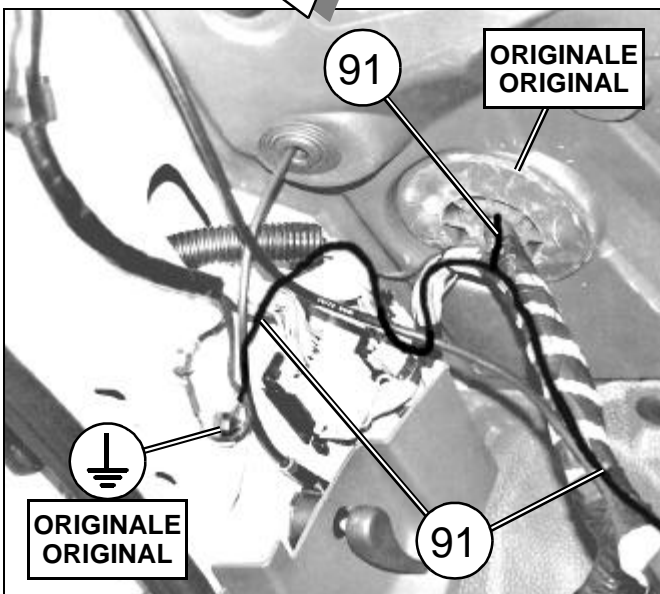
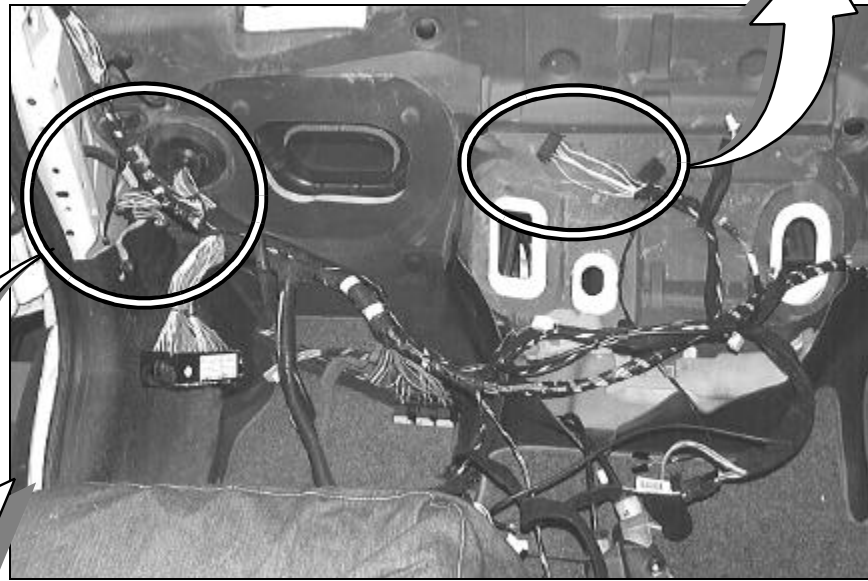

17D

RHD

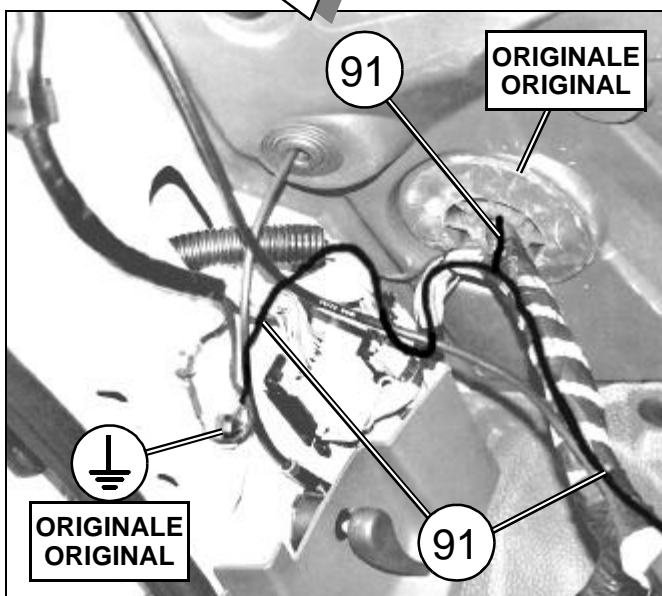
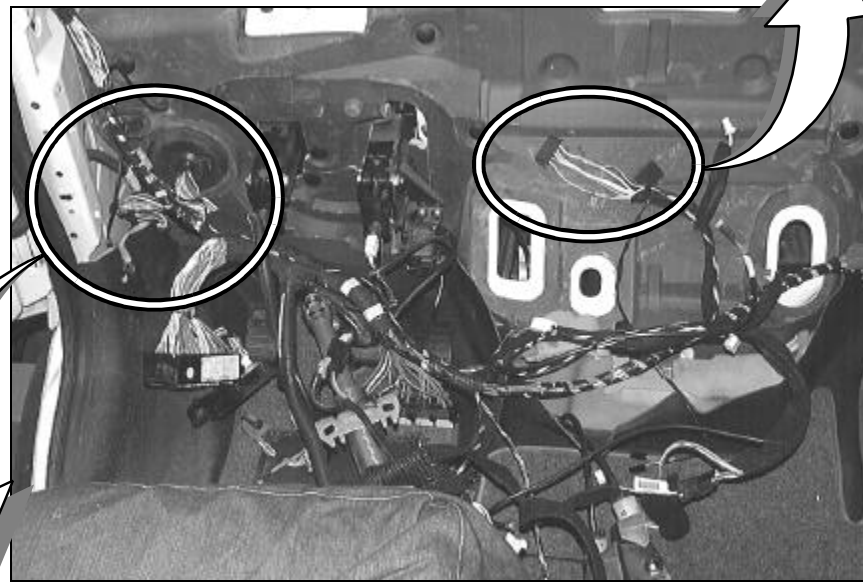
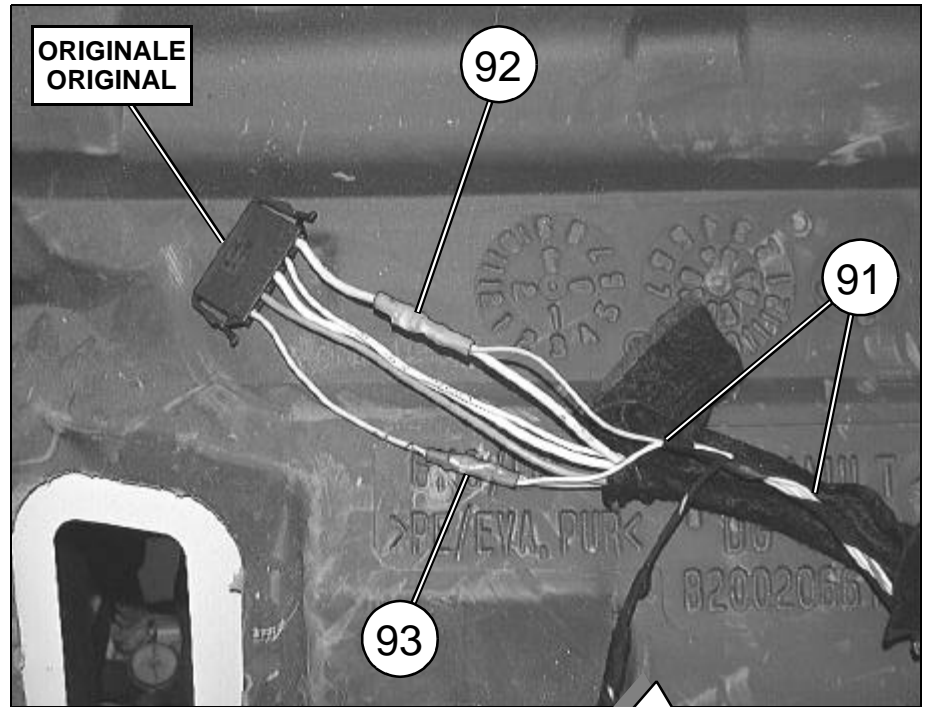

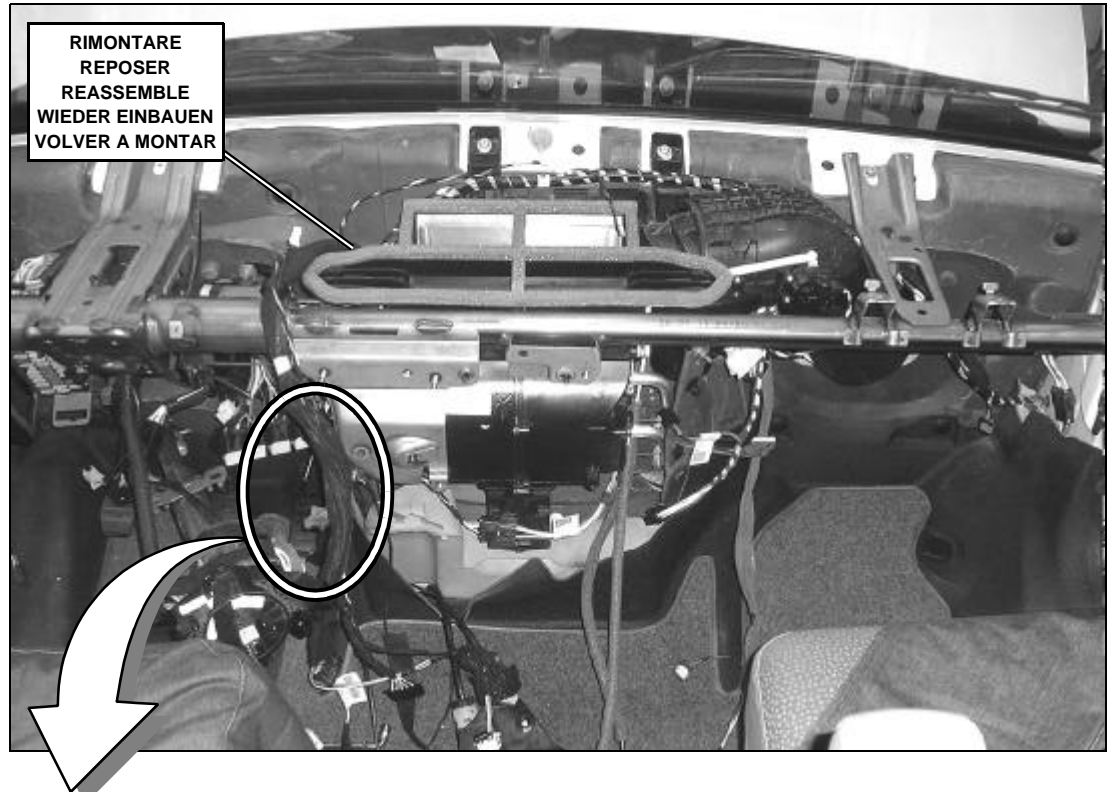

18D

LHD

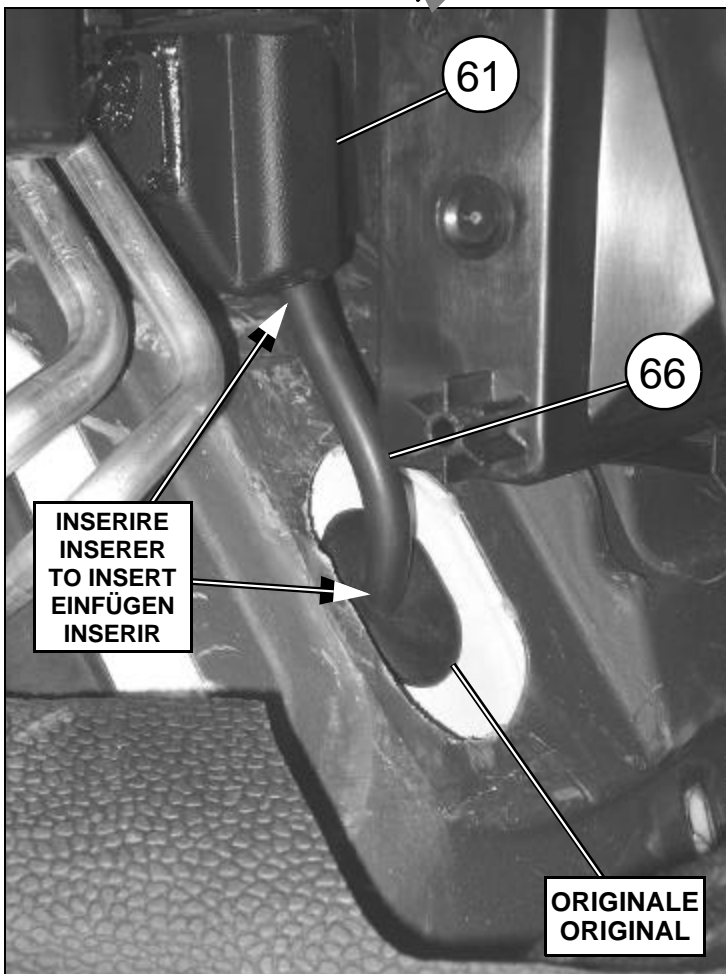

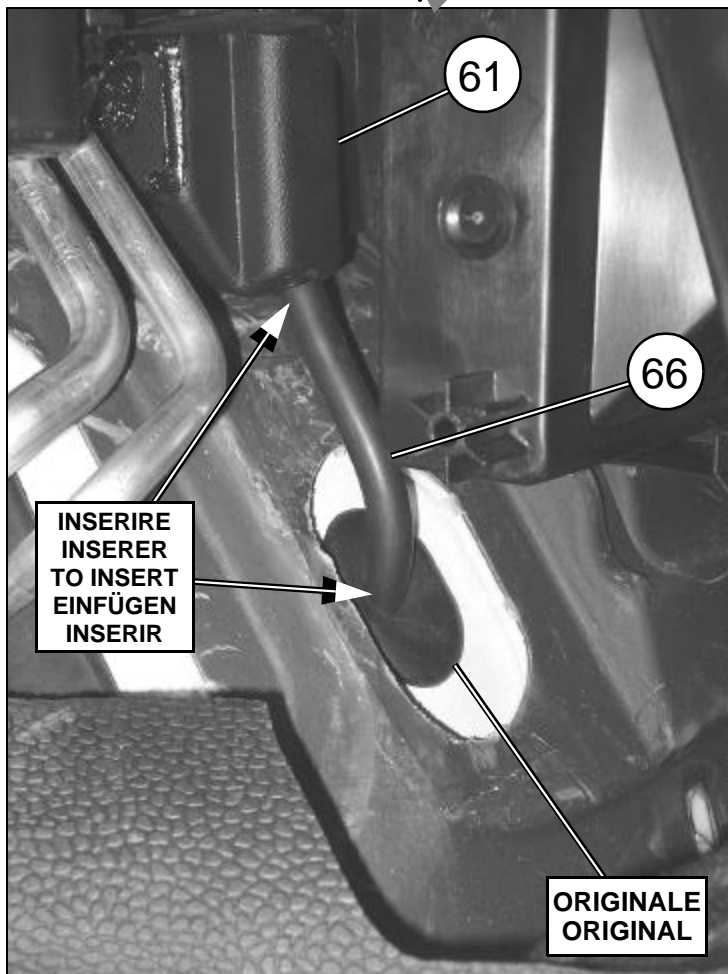
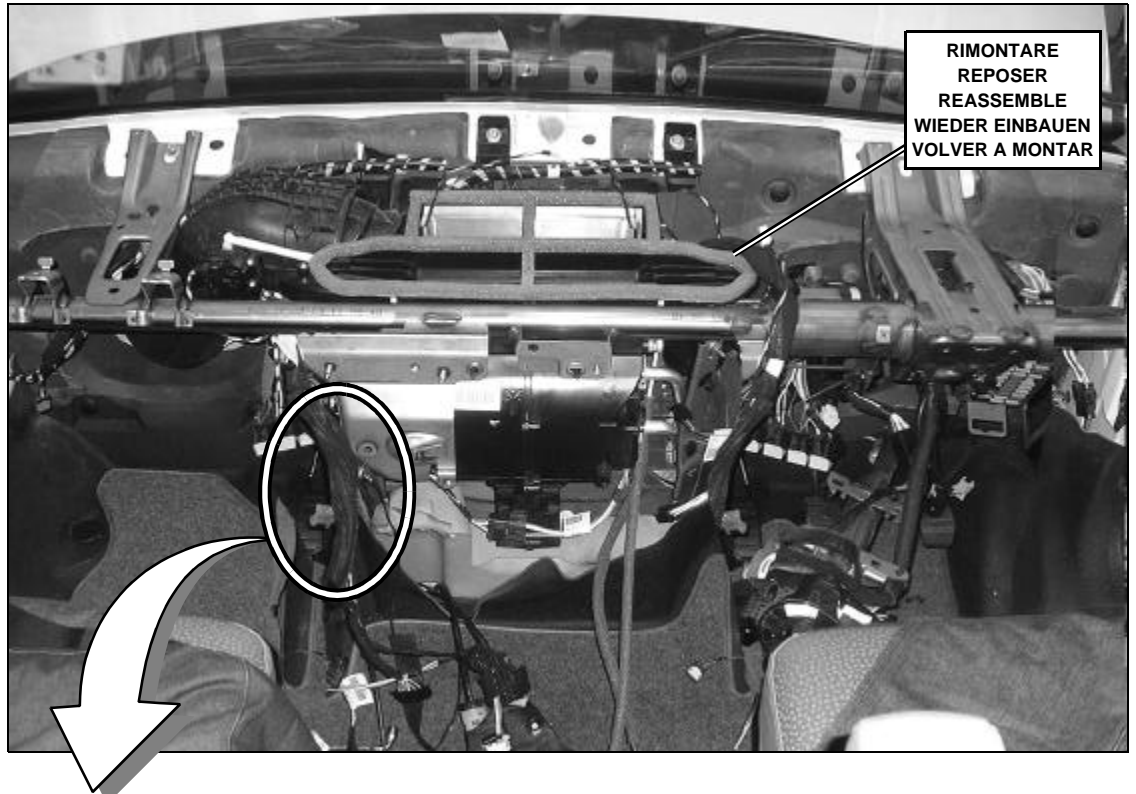

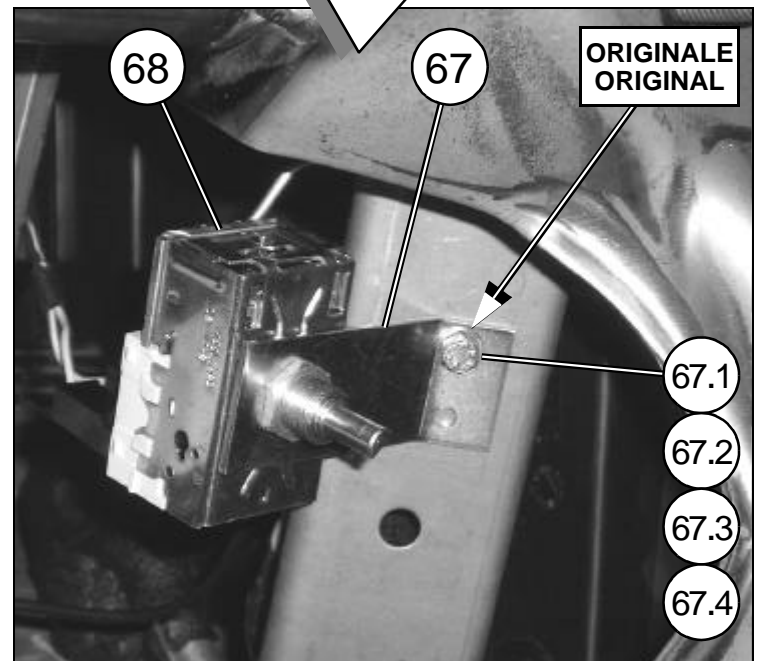
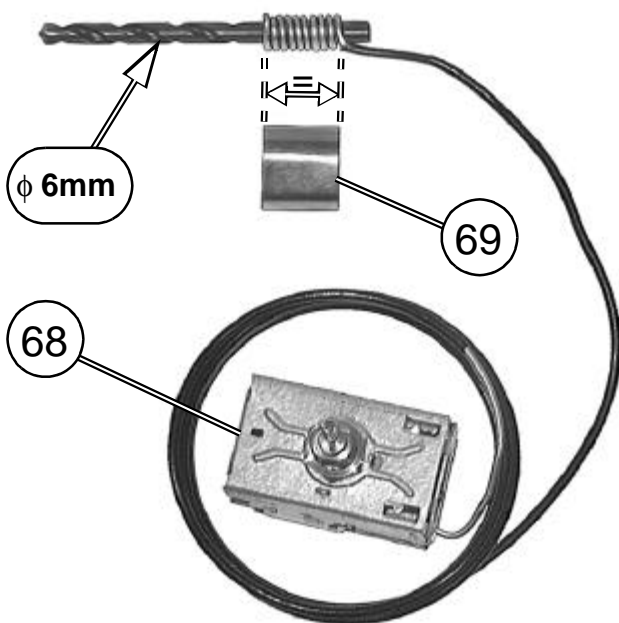
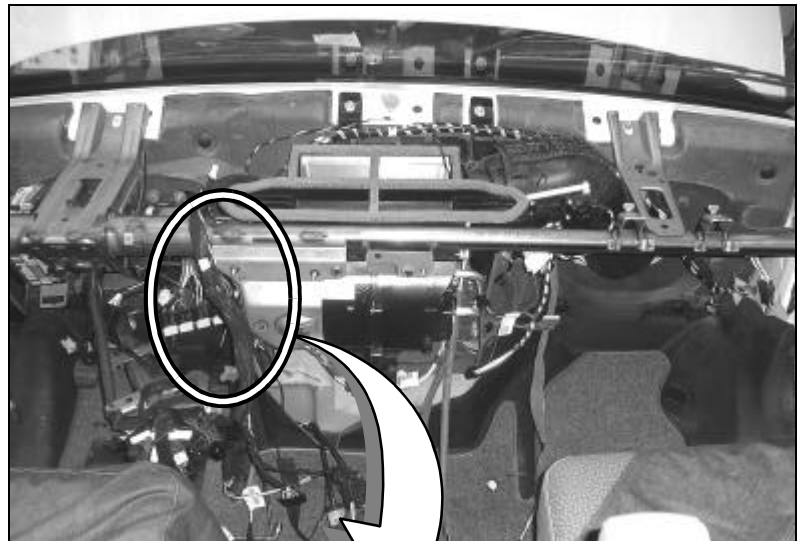
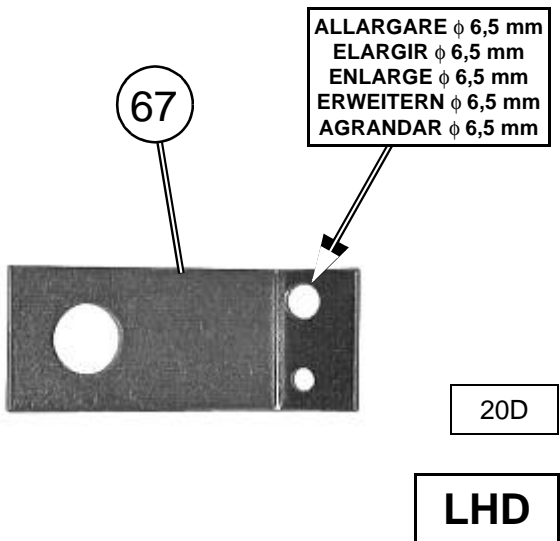

ELEMENTI DI FISSAGGIO PIECES DE FIXATION / FIXING PARTS BEFESTIGUNGSELEMENTE ELEMENTOS DE FIJACION		
Pos.	Tipologia / Typologie Typology / Tipologie Tipologia	Descrizione / Description Description / Beschreibung Descripción
67.1		M6x16
67.2		ϕ 6
67.3		ϕ 6x ϕ 18x2
67.4		M6

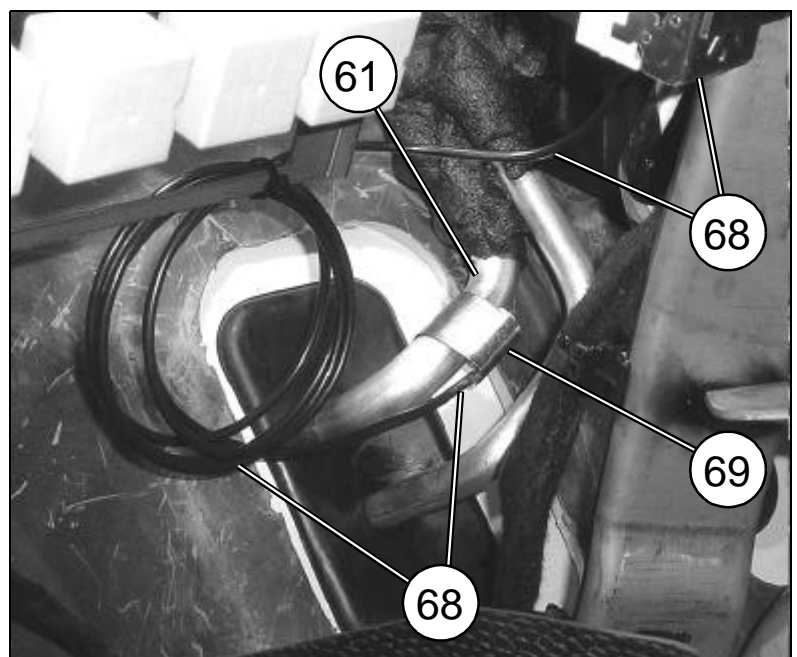

ALLARGARE ϕ 6,5 mm
 ELARGIR ϕ 6,5 mm
 ENLARGE ϕ 6,5 mm
 ERWEITERN ϕ 6,5 mm
 AGRANDAR ϕ 6,5 mm

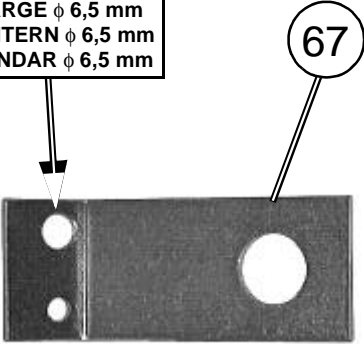

67

21D

RHD

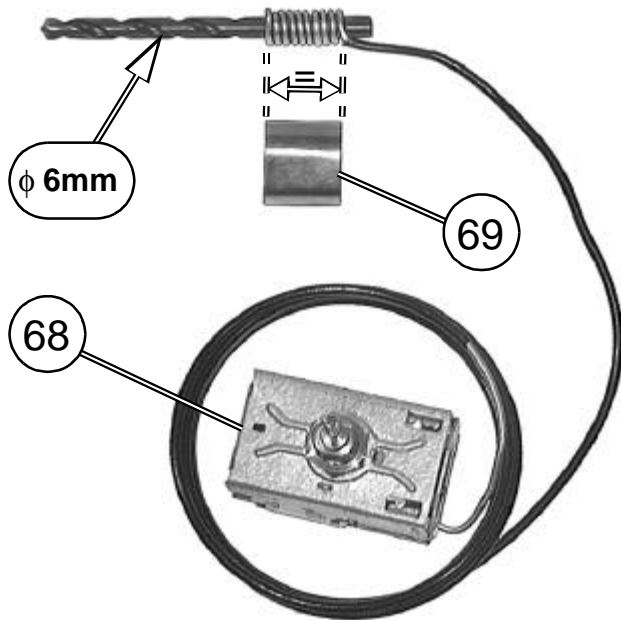
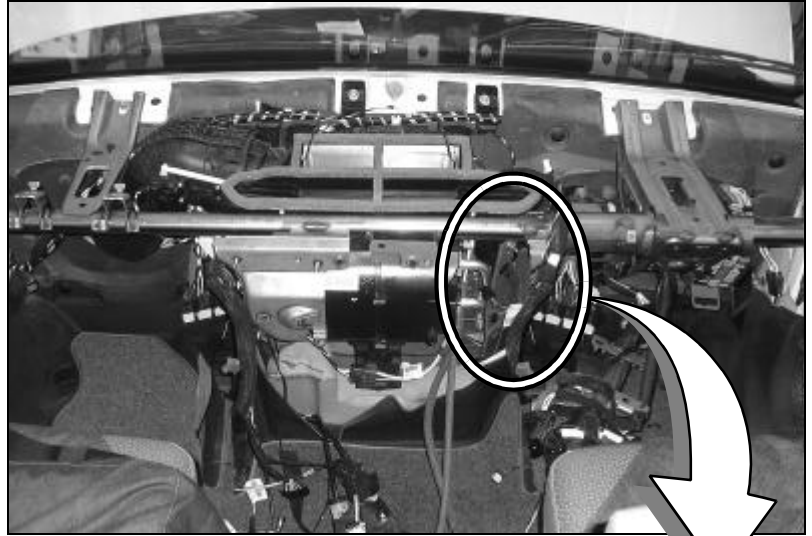

ϕ 6mm

69

68

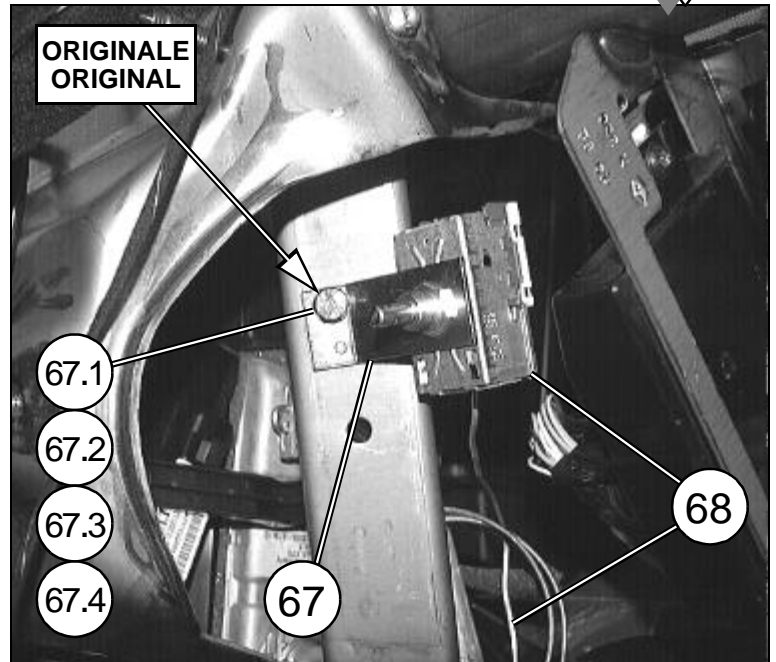

ORIGINALE ORIGINAL

67.1

67.2

67.3

67.4

67

68

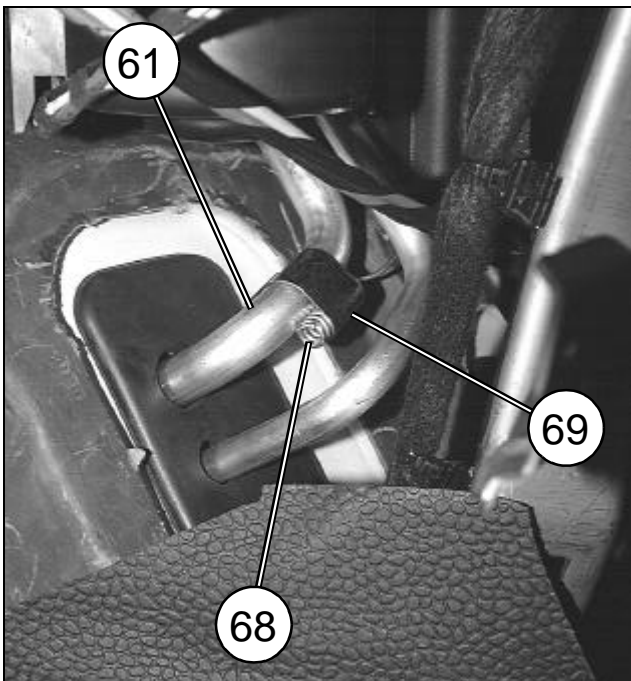

61

69

68

ELEMENTI DI FISSAGGIO / PIECES DE FIXATION / FIXING PARTS BEFESTIGUNGSELEMENTE ELEMENTOS DE FIJACION		
Pos.	Tipologia / Typologie Typology / Tipologie Tipologia	Descrizione / Description Description / Beschreibung Descripción
67.1		M6x16
67.2		ϕ 6
67.3		ϕ 6x ϕ 18x2
67.4		M6

LHD

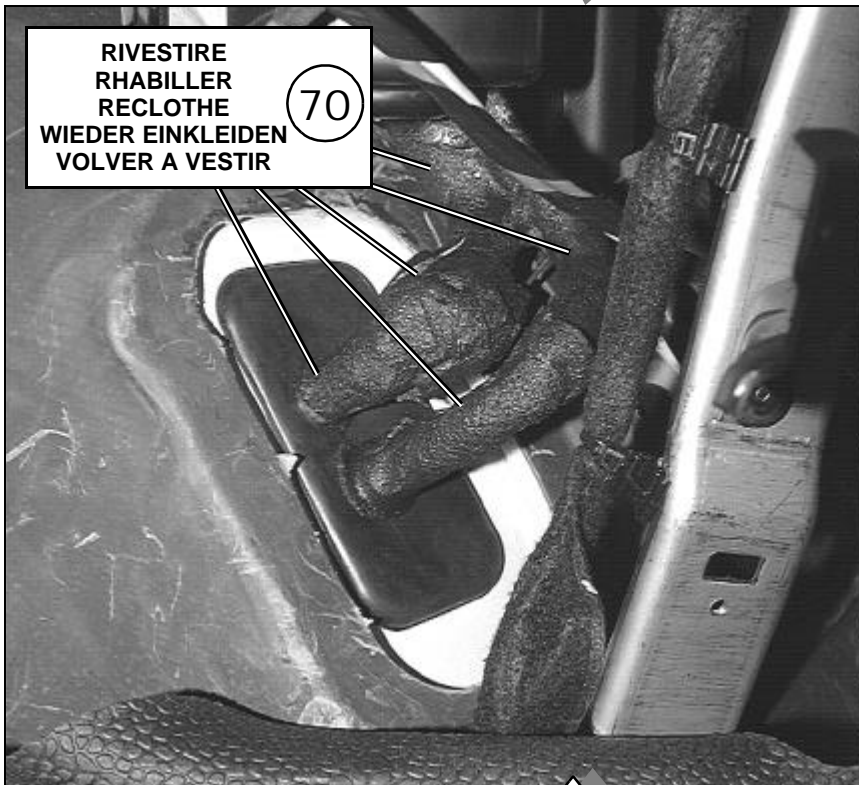

22D

RHD



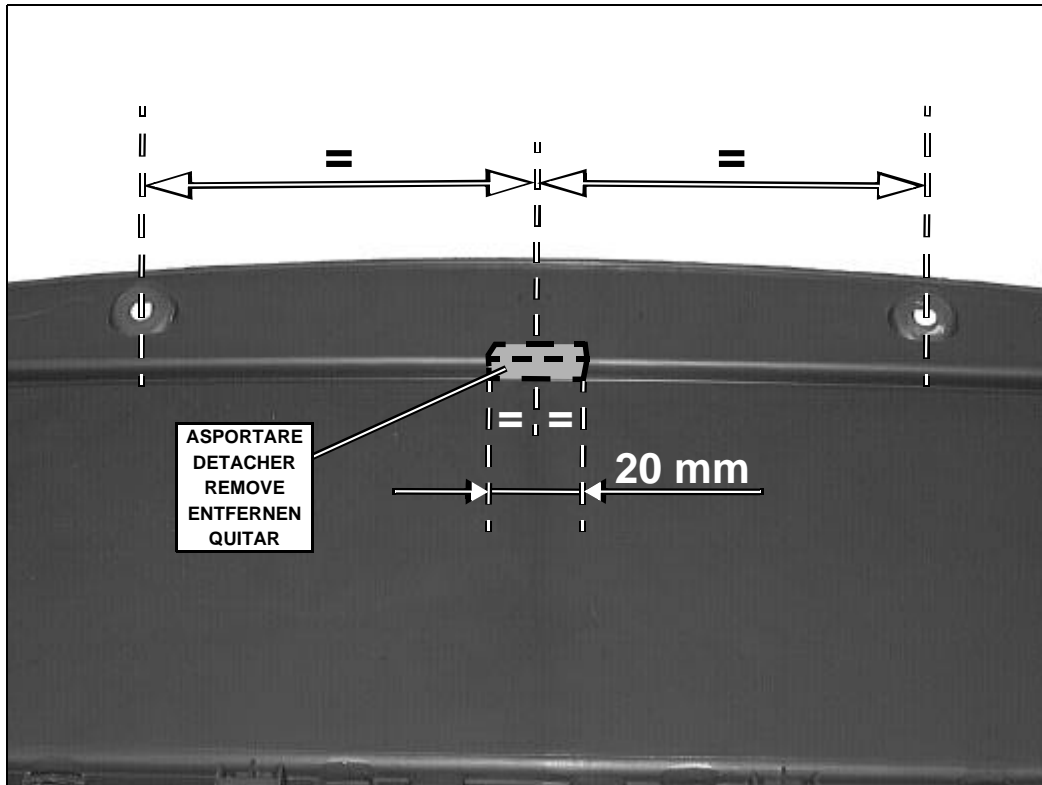

23D

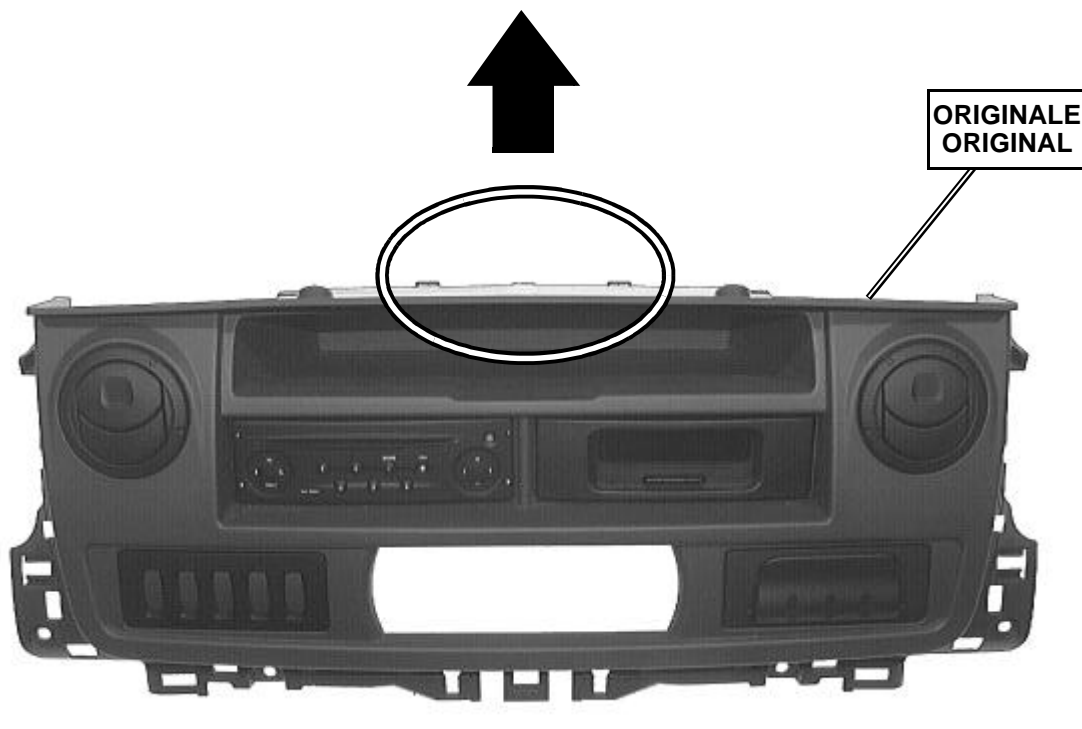

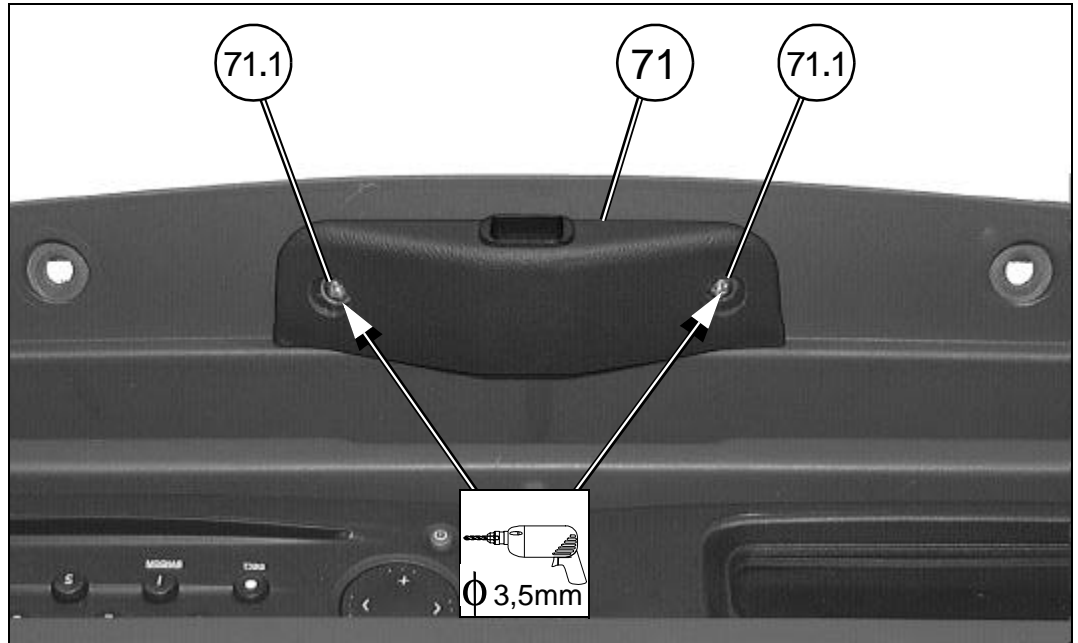

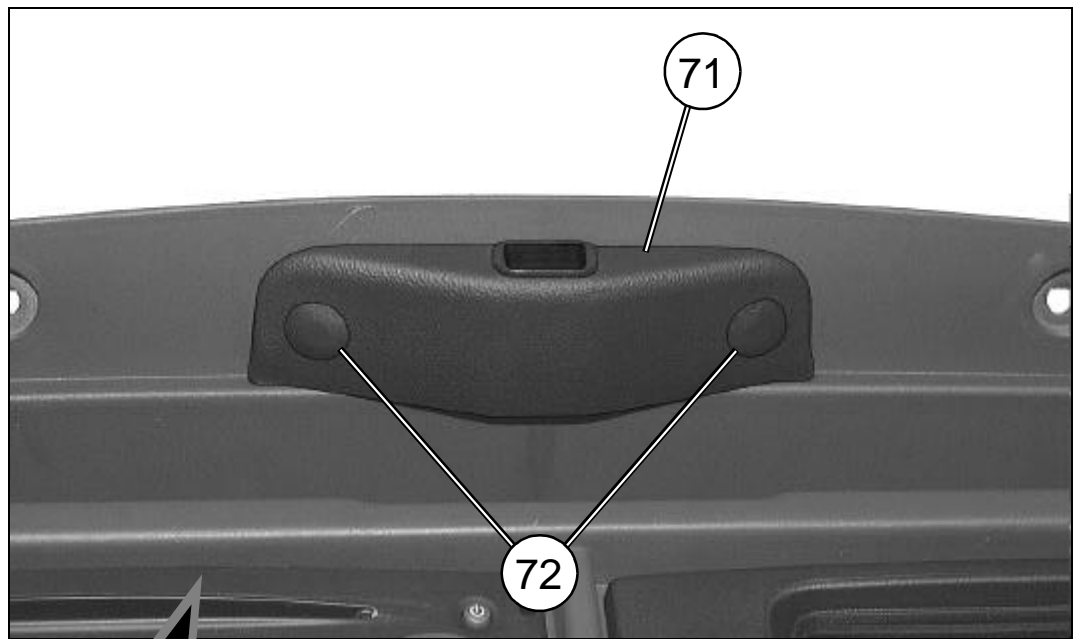

24D

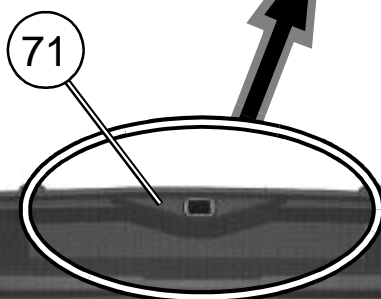

ORIGINALE
ORIGINAL



ELEMENTI DI FISSAGGIO PIECES DE FIXATION / FIXING PARTS BEFESTIGUNGSELEMENTE ELEMENTOS DE FIJACION		
Pos.	Tipologia Typologie Typology Tipologie Tipologia	Descrizione Description Description Beschreibung Descripción
71.1	 	4,2x9,5

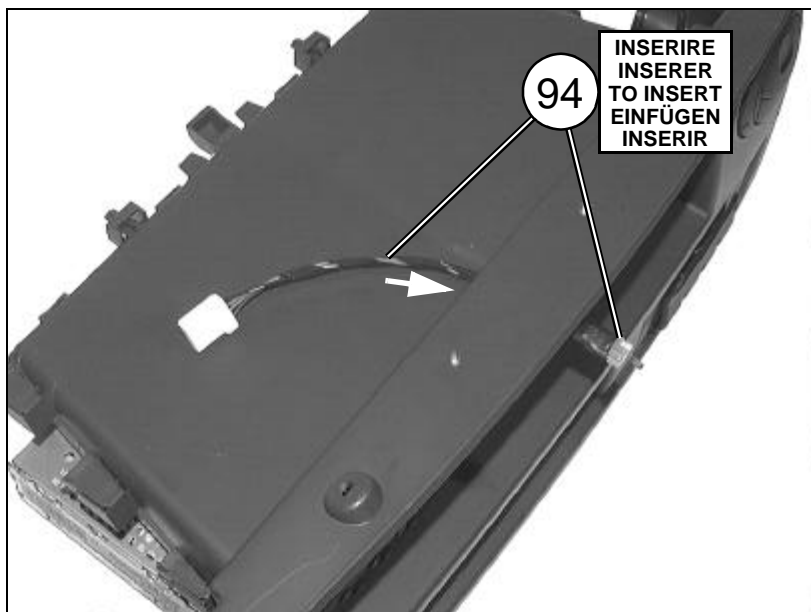

25D

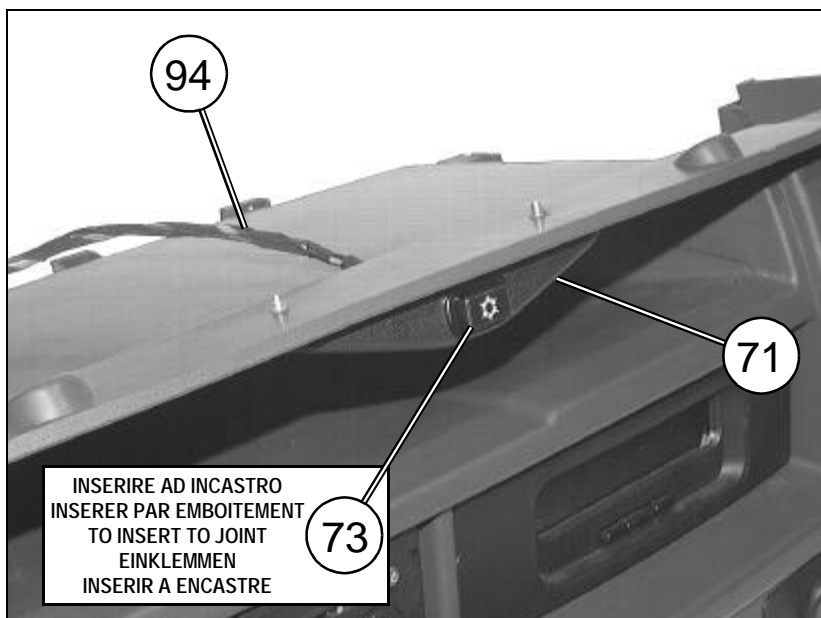
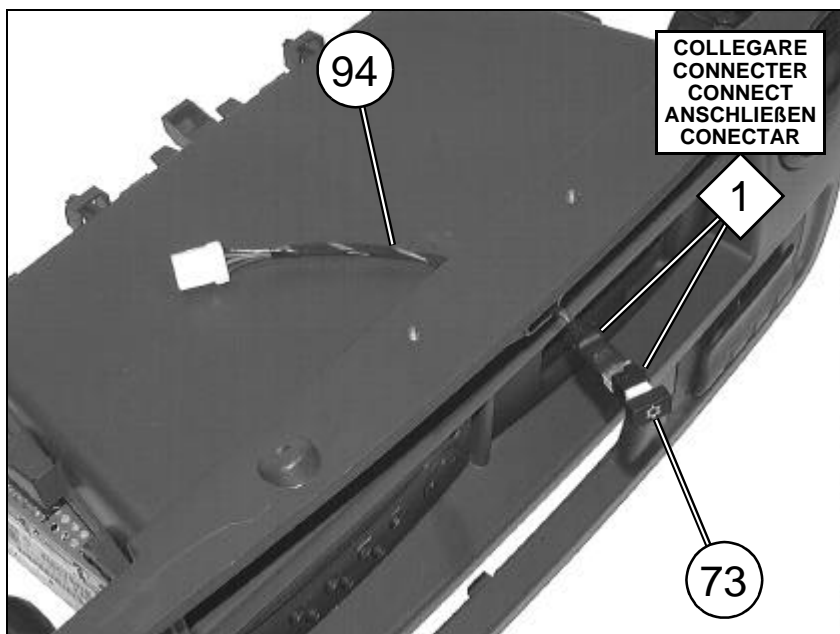

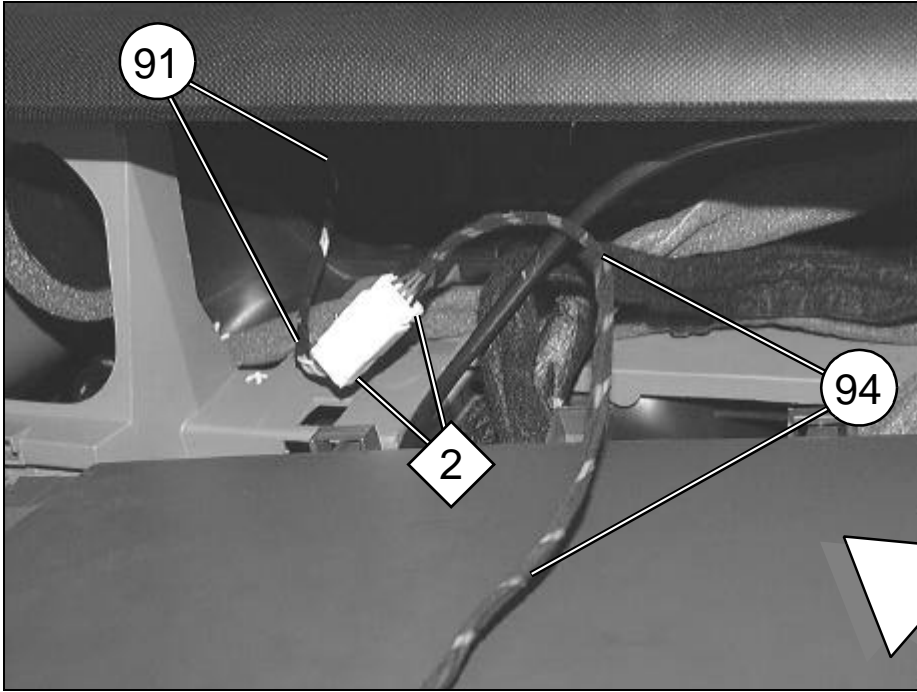

26D





27D

COLLEGAMENTO TUBI GAS-INSTALLAZIONE COMPONENTI ELETTRICI NEL VANO MOTORE
RACCORDAMENTO DES TUYAUX GAZ-INSTALLATION COMPOSANTS ELECTRIQUES DANS LE COMPARTIMENT MOTEUR
GAS PIPE CONNECTION-INSTALLATION OF ELECTRICAL COMPONENTS IN THE ENGINE COMPARTMENT
KAEITEMITTELSCHLAUCHVERBINDUNG-INSTALLATION DER ELEKTRISCHEN TEILE IM MOTORRAUM
CONEXION TUBOS GAS-INSTALACION COMPONENTES ELECTRICOS EN EL COMPARTIMENTO MOTOR

MATERIALE FORNITO / MATERIEL FOURNI / SUPPLIED MATERIAL / GELIEFERTES MATERIAL / MATERIAL ABASTECIDO

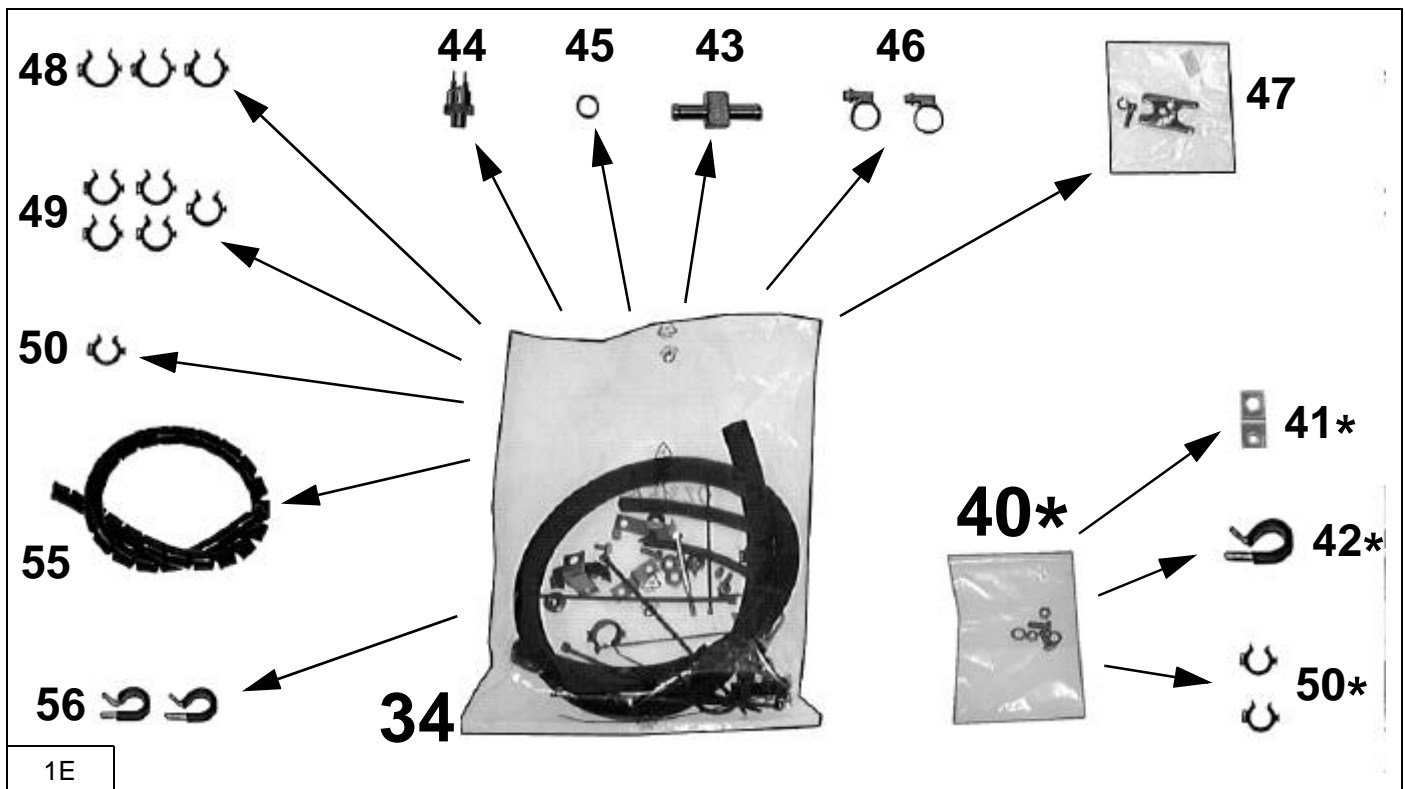

Pos.	Descrizione / Description / Description / Beschreibung / Descripción	Codice / Code / Kode / Código
34	Sacchetto accessori	0231663/0
40*	Sacchetto accessori	0231732/0
41*	Staffa di supporto tubi gas	0811219/0
42*	Fascetta in gomma	069033/0
43	Raccordo per bulbo termostatico	007647/0
44	Bulbo termostatico	0681209/0
45	Rondella per bulbo termostatico	007145/0
46	Fascetta	0361740/0
47	Sacchetto flangia	043066/1
48	Fermatubo ϕ 24	069637/0
49	Fermatubo ϕ 22	069636/0
50	Fermatubo ϕ 18	069635/0
55	Protezione a spirale	070494/0
56	Fascetta in gomma	069032/0
*	Componente fornito nel Kit A03988 / Composant fourni dans le kit A03988 Component supplied in KIT A03988 / Mit Einbausatz A03988 gelieferte Einbauteile Componente abastecido en el KIT A03988	

MATERIALE FORNITO / MATERIEL FOURNI / SUPPLIED MATERIAL / GELIEFERTES MATERIAL / MATERIAL ABASTECIDO

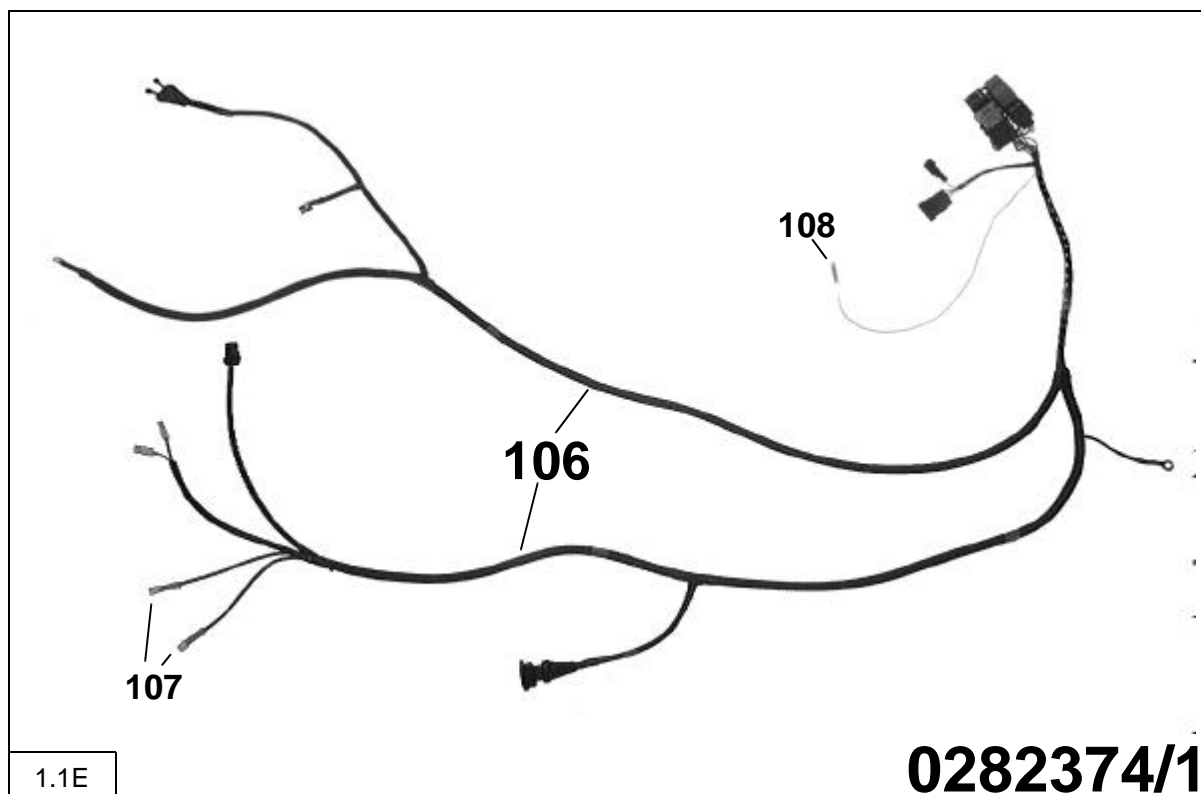

Pos.	Descrizione / Description / Description / Beschreibung / Descripción	Codice / Code / Kode / Código
106	Impianto elettrico Elettroventole	0282374/1
107	Giunzione RAYCHEM GIALLA	064272/0
108	Giunzione RAYCHEM BLU	064273/0

TUBI GAS / TUYAUX GAZ / GAS PIPE / KAEITEMITTELSCHLÄUCHE / TUBOS GAS		
	Descrizione / Description / Description / Beschreibung / Descripción	Codice / Code / Kode / Código
	Tubo gas 5/16"CF (condensatore-filtro)	806D825
	Tubo gas 5/16"FE (filtro-evaporatore)	806D826/1
*	Tubo gas 13/32"CC (compressore-condensatore)	808D961
*	Tubo gas 1/2"EC (evaporatore-compressore)	810D962
*	Componente fornito nel Kit A03988 / Composant fourni dans le kit A03988 / Component supplied in KIT A03988 Mit Einbausatz A03988 gelieferte Einbauteile / Componente abastecido en el KIT A03988	

POSIZIONAMENTO IMPIANTO ELETTRICO NEL VANO MOTORE (vedi schema elettrico allegato)
POSITIONNEMENT DU FAISCEAU ELECTRIQUE DANS LE COMPARTIMENT MOTEUR (voir schéma électrique joint)
POSITIONING THE ELECTRIC SYSTEM WIRING WITHIN THE ENGINE COMPARTMENT (see the enclosed wiring diagram)
POSITIONIERUNG DER ELEKTRISCHEN ANLAGE IM MOTORRAUM (siehe Schaltschema im Anhang)
COLOCACIÓN DE LA INSTALACIÓN ELÉCTRICA EN EL ESPACIO MOTOR (véase esquema eléctrico adjunto)

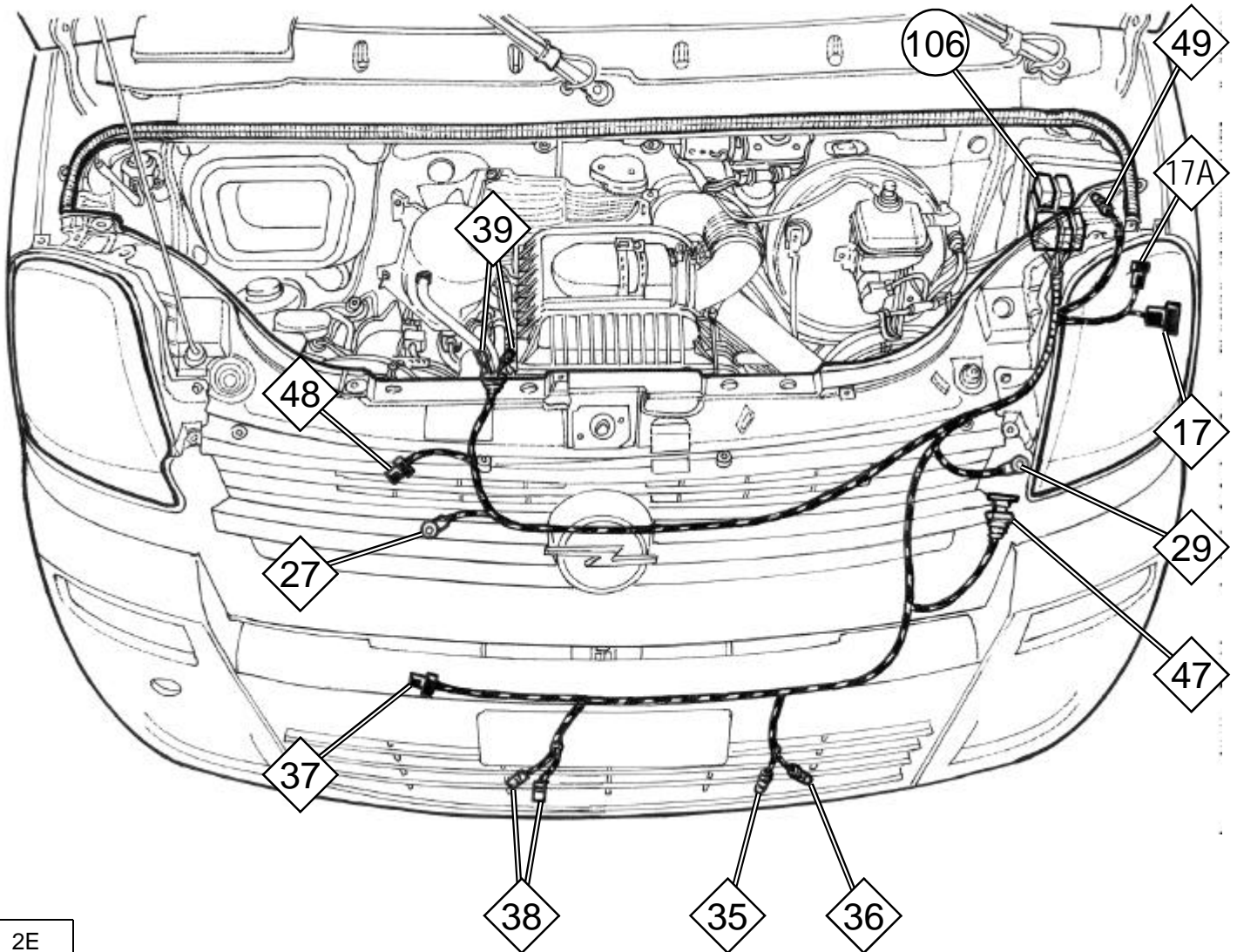

2E

3E

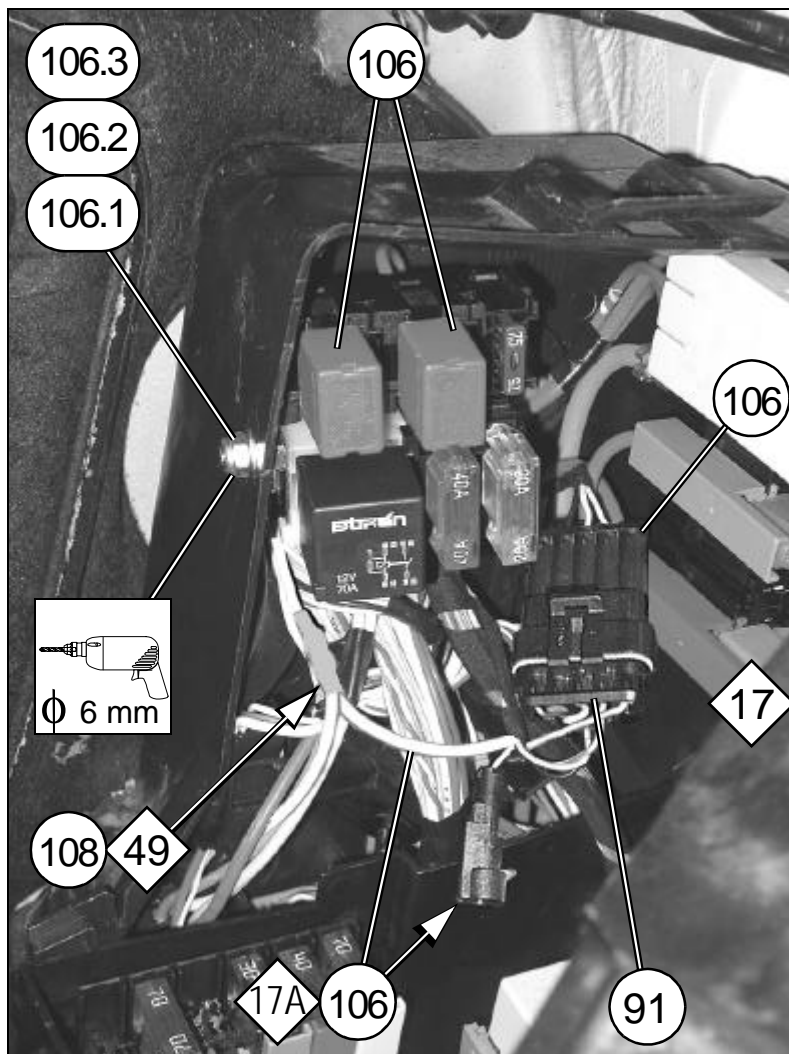

ELEMENTI DI FISSAGGIO PIECES DE FIXATION / FIXING PARTS BEFESTIGUNGSELEMENTE ELEMENTOS DE FIJACION		
Pos.	Tipologia / Typologie Typology / Tipologie Tipologia	Descrizione / Description Description / Beschreibung Descripción
106.1		M6x16
106.2		ϕ 6
106.3		M6

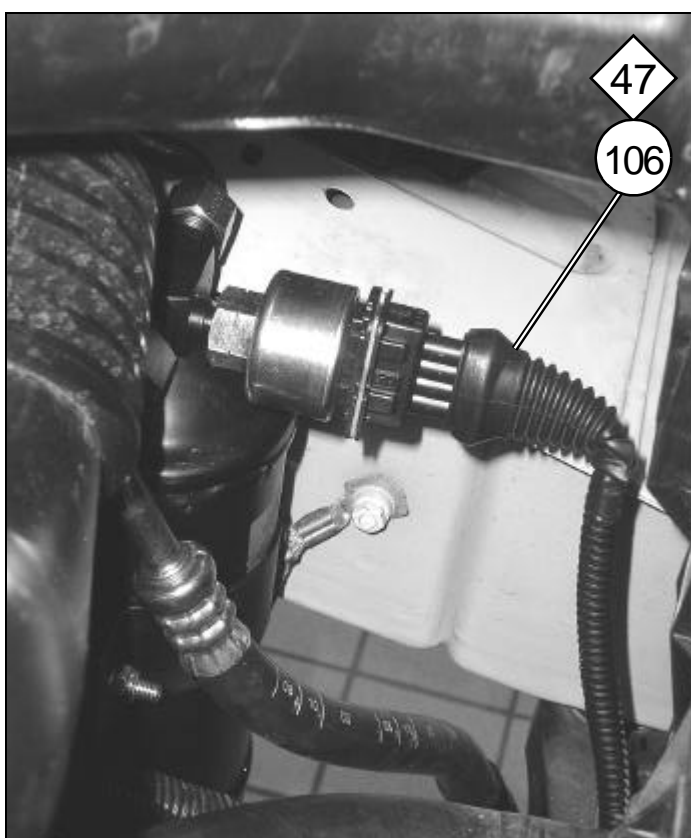

4E

5E

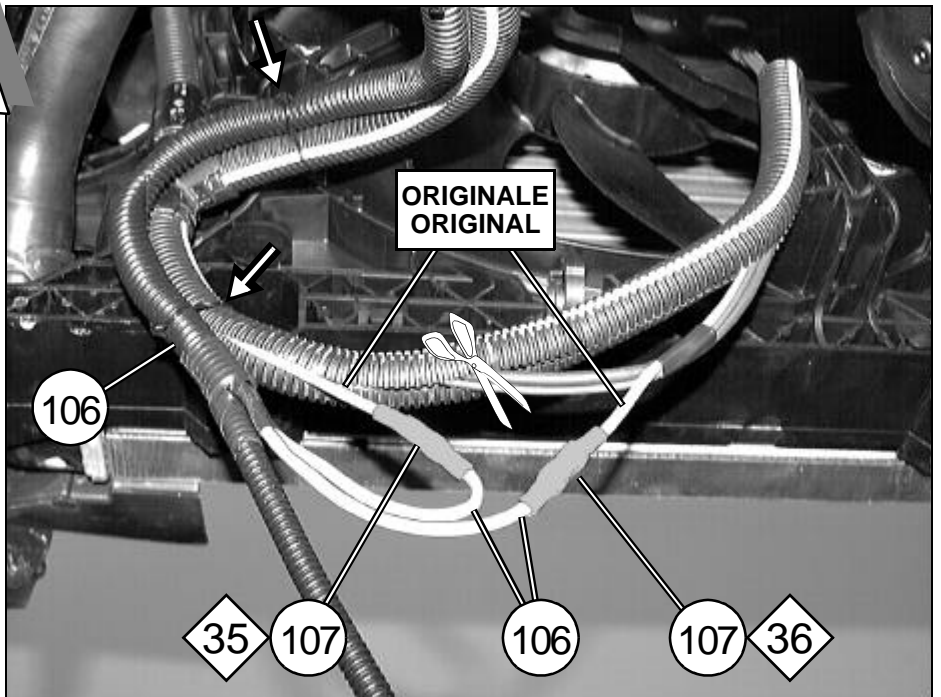
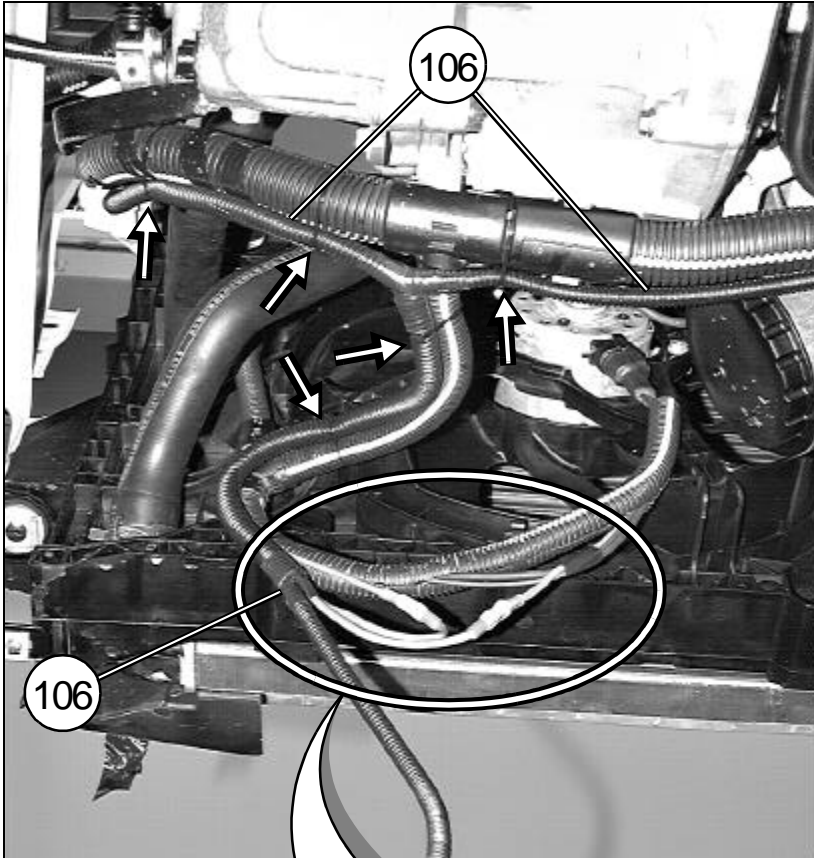

ELEMENTI DI FISSAGGIO / PIÈCES DE FIXATION / FIXING PARTS BEFESTIGUNGSELEMENTE / ELEMENTOS DE FIJACION		
Pos.	Tipologia / Typologie / Typology Tipologie / Tipologia	Descrizione / Description / Description Beschreibung / Descripción
		Fascetta a strappo

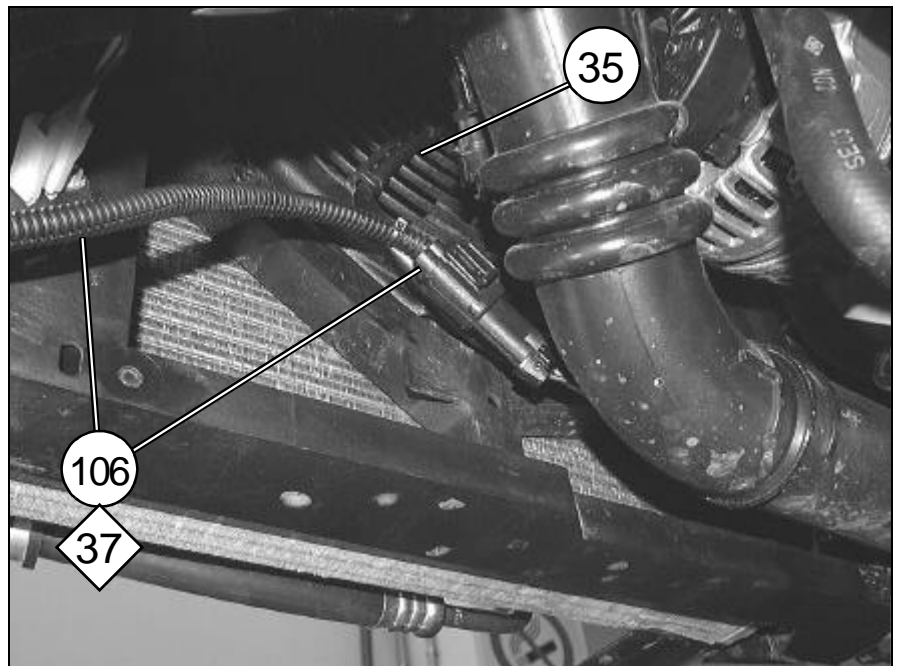
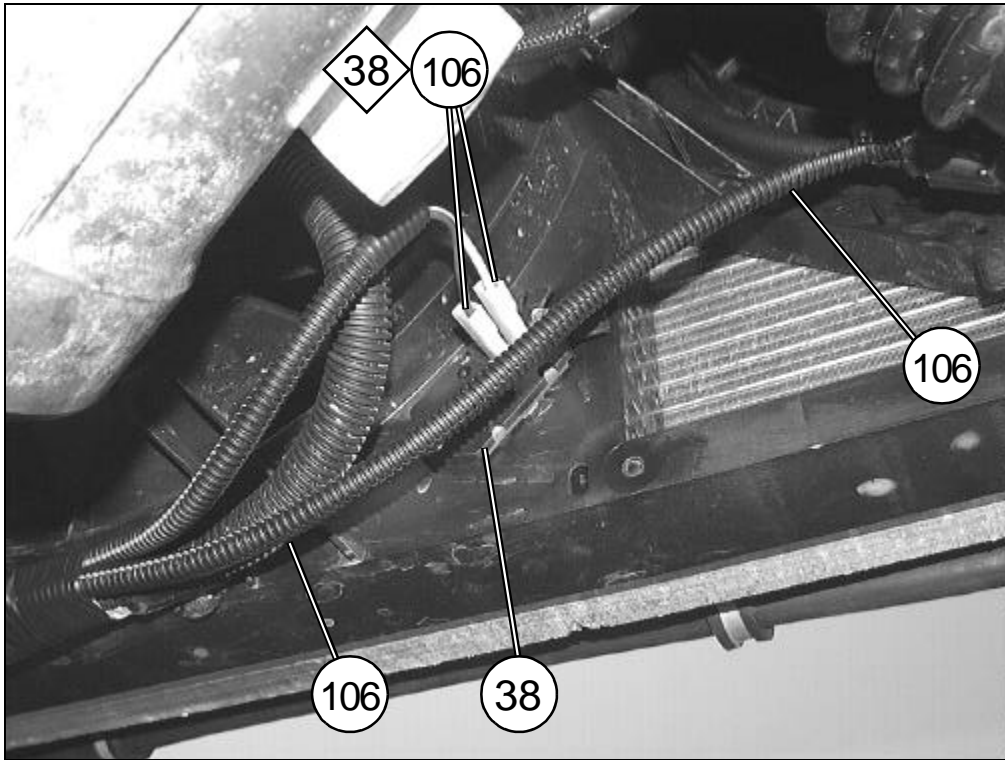

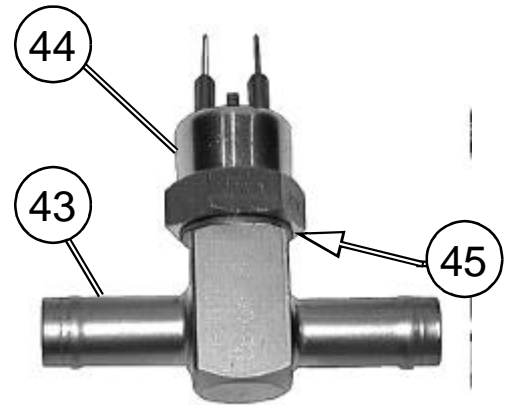
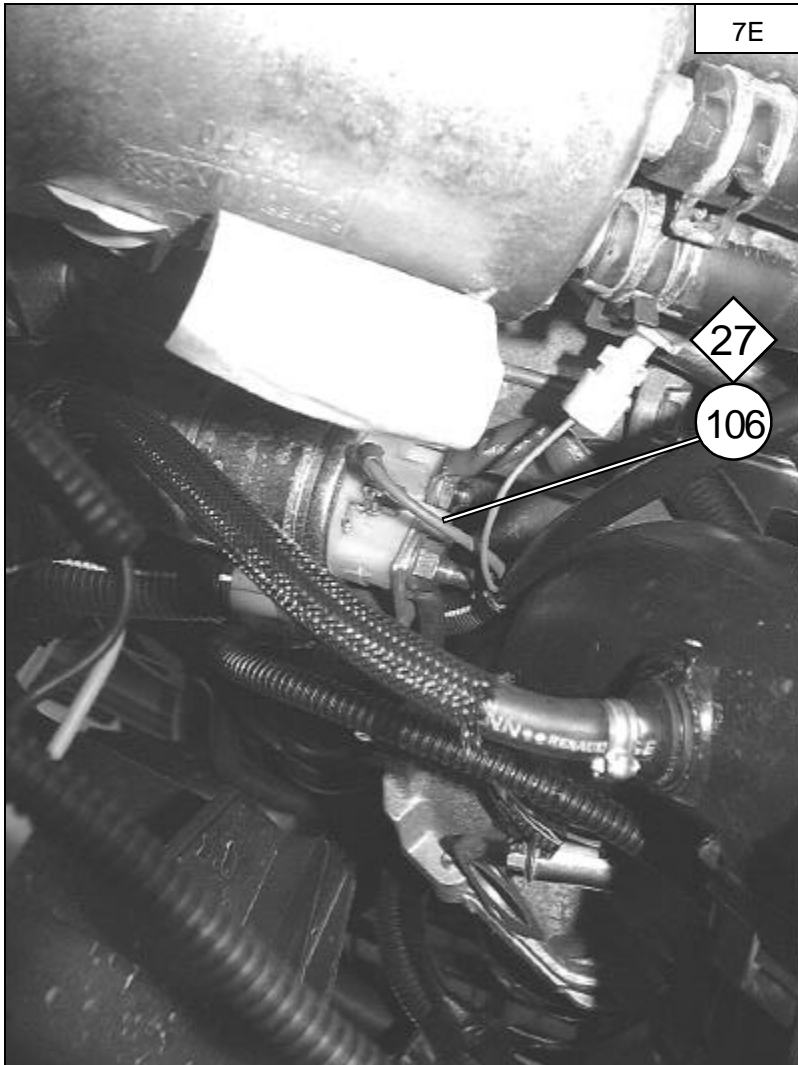

8E

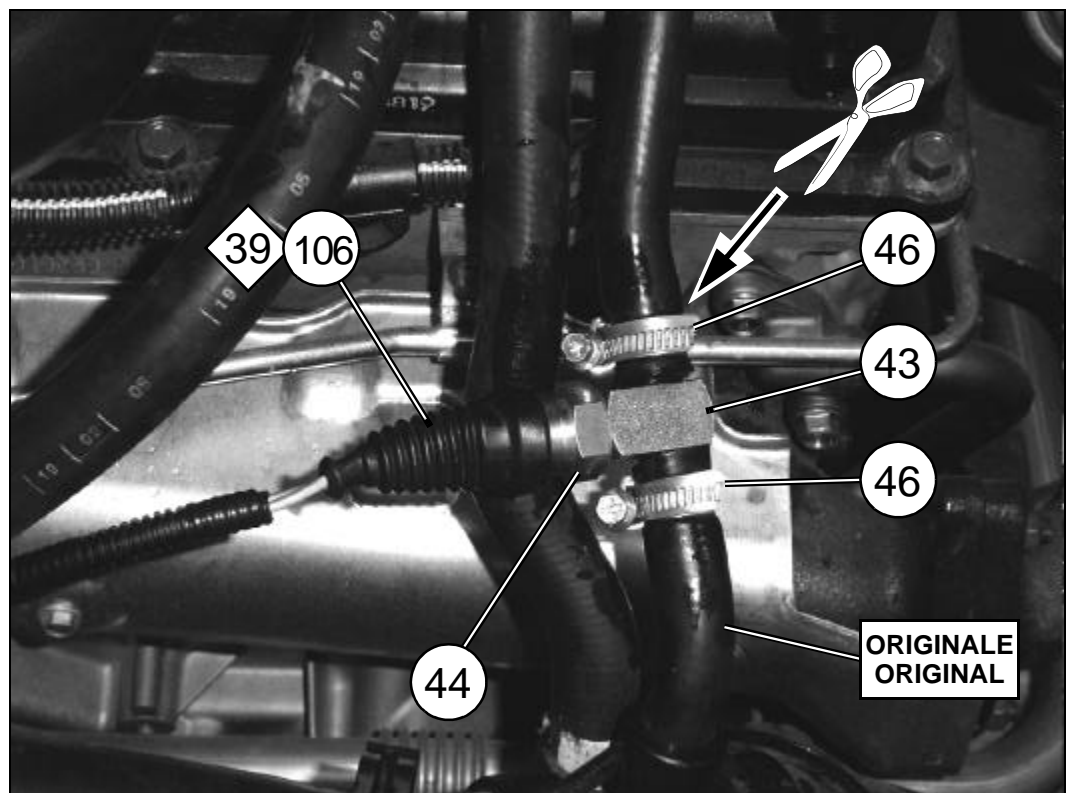

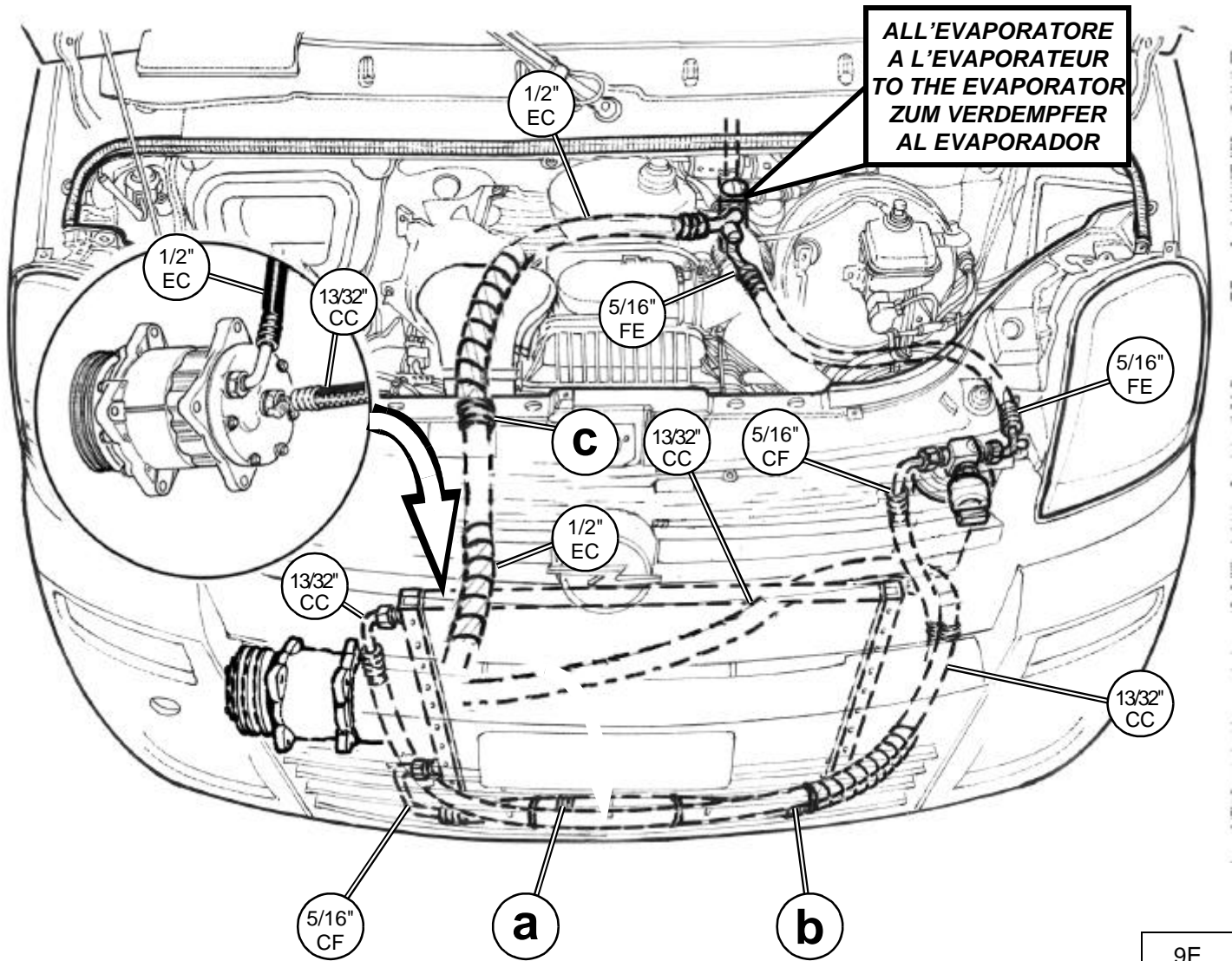

ALL'EVAPORATORE
A L'EVAPORATEUR
TO THE EVAPORATOR
ZUM VERDEMPFER
AL EVAPORADOR

9E

R134a
Kg.0,750(±0,025)

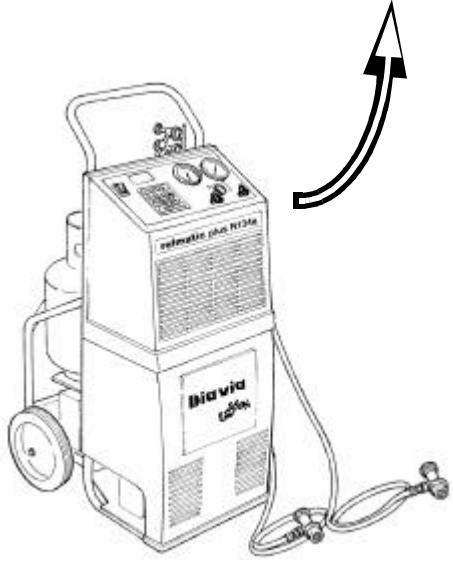

- (I) **Vista complessiva passaggio tubi gas nel vano motore.**
Alle posizioni "a-b-c" sono evidenziati i punti di fissaggio tubi alla vettura, descritti in particolare nelle figure che seguono.
- (F) **Vue d'ensemble du passage des tuyaux gaz dans le compartiment moteur.**
Les points de fixation des tuyaux à la voiture, décrits en détail sur les figures qui suivent, sont mis en évidence aux positions "a-b-c".
- (GB) **General view of the gas hoses in the engine compartment.**
Positions "a-b-c" indicate the points for securing pipes to the vehicle, described in detail in the following figures.
- (D) **Gesamtansicht des Durchgangs der Kältemittelschläuche im Motorraum.**
Bei den Positionen "a-b-c" sind die Befestigungspunkte der Schläuche am Fahrzeug hervorgehoben.
- (E) **Vista total paso tubos gas en el compartimento motor.**
En las posición "a-b-c" se evidencian los puntos de sujeción de los tubos al coche, descritos detalladamente en las figuras que siguen.

**ELEMENTI DI FISSAGGIO / PIECES DE FIXATION
FIXING PARTS / BEFESTIGUNGSELEMENTE
ELEMENTOS DE FIJACION**

Pos.	Tipologia Typologie Typology Tipologie Tipologia	Descrizione Description Description Beschreibung Descripción	Codice Code Kode Codigo
47.1		Flangia tubi gas	043061/1
47.2		M6x16	-
47.3		φ6	-

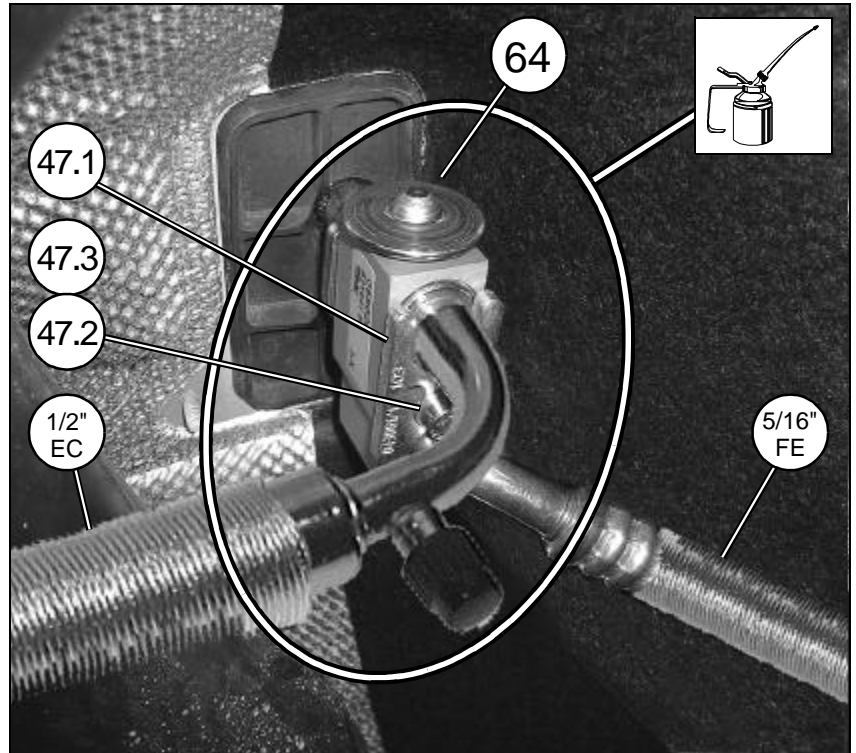

10E

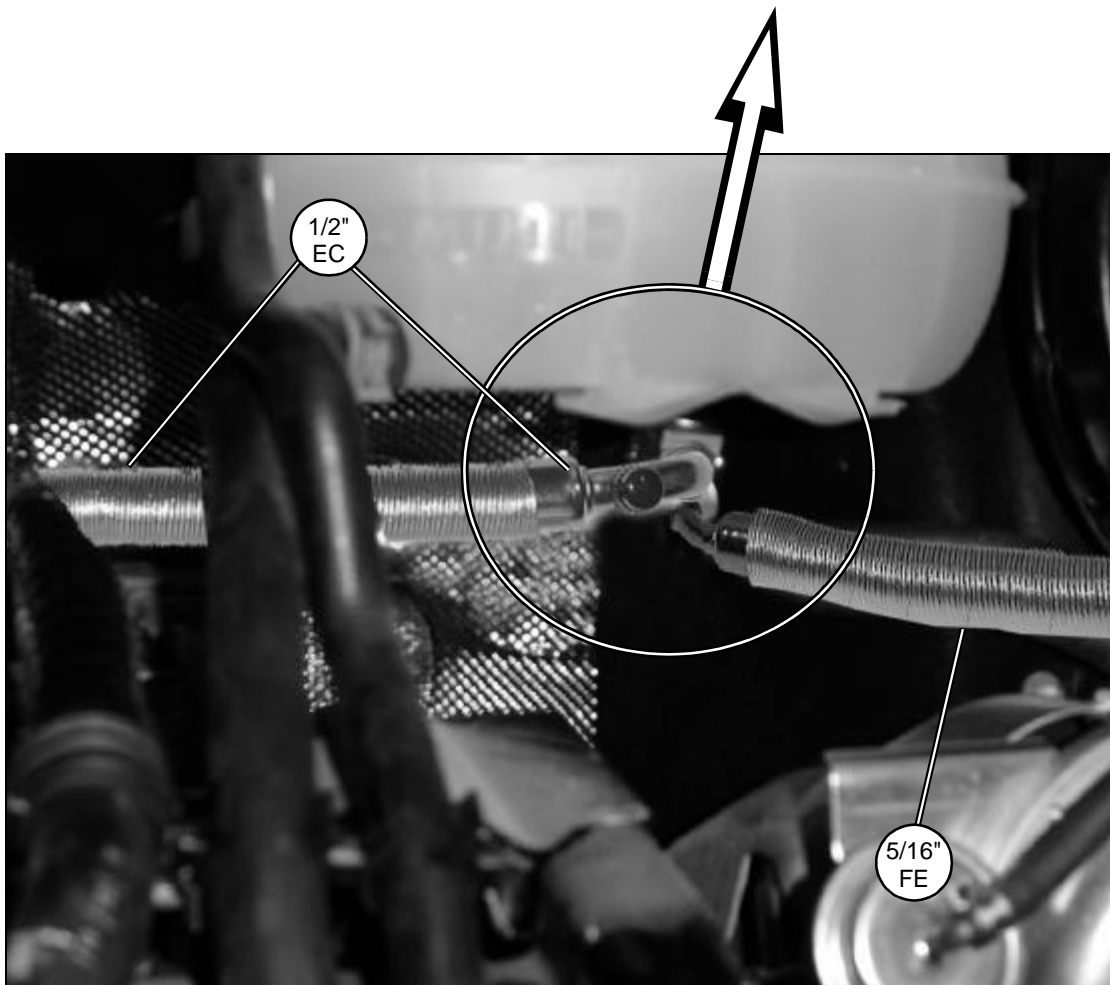

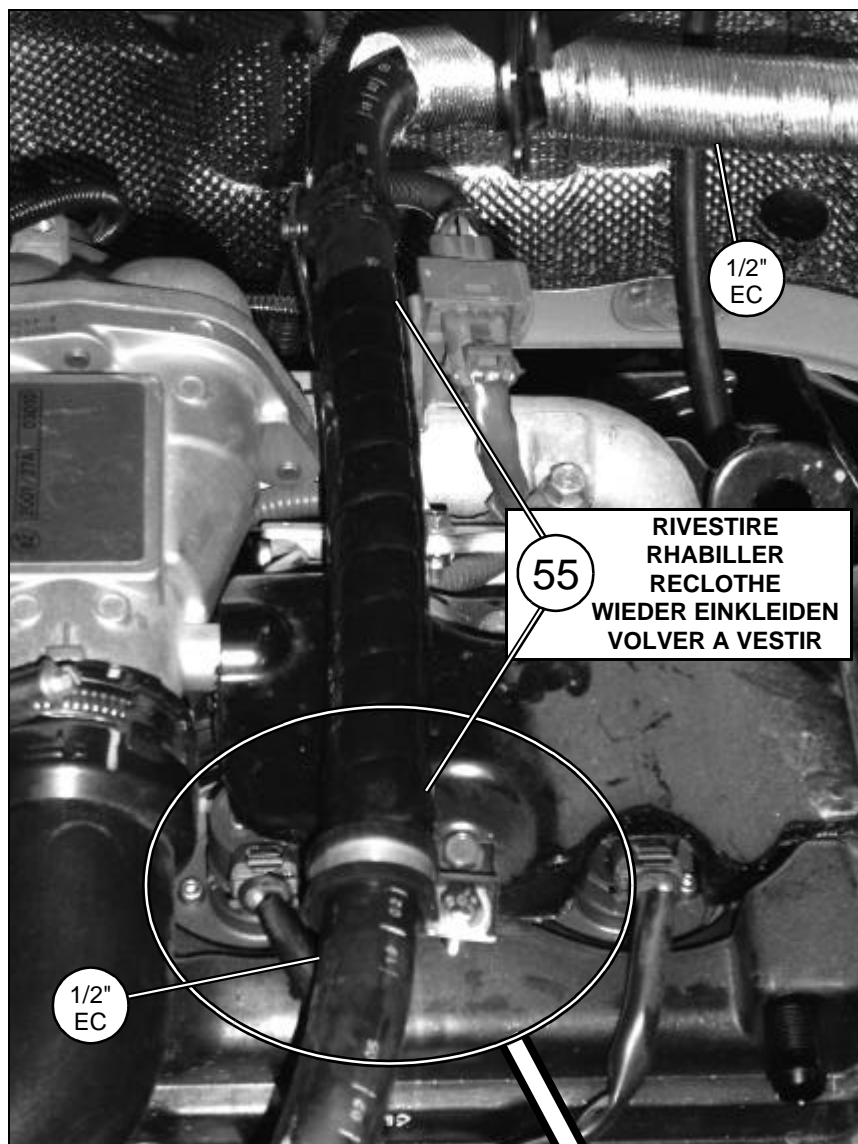

55
RIVESTIRE
RHABILLER
RECLOTHE
WIEDER EINKLEIDEN
VOLVER A VESTIR

ELEMENTI DI FISSAGGIO / PIECES DE FIXATION
FIXING PARTS / BEFESTIGUNGSELEMENTE
ELEMENTOS DE FIJACION

Pos.	Tipologia Typologie Typology Tipologie Tipologia	Descrizione Description Description Beschreibung Descripción
42.1		M6x16
42.2		M6

11E

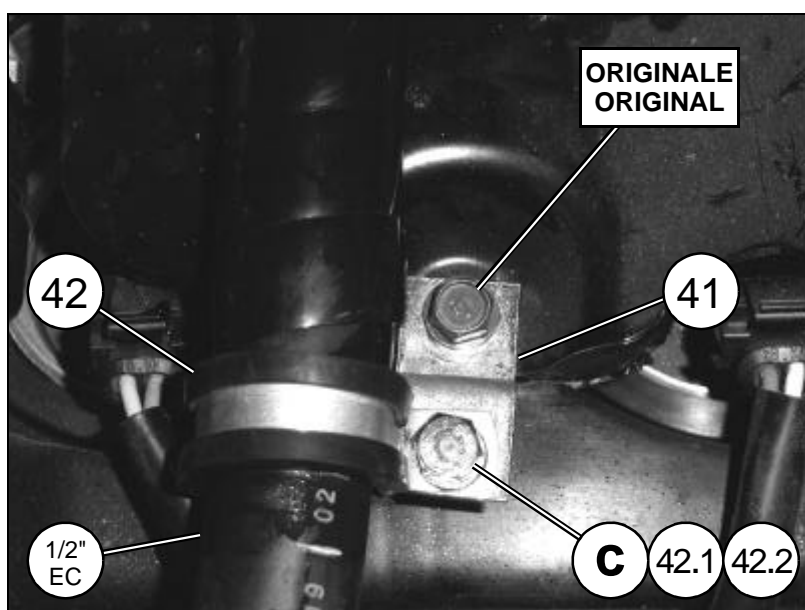

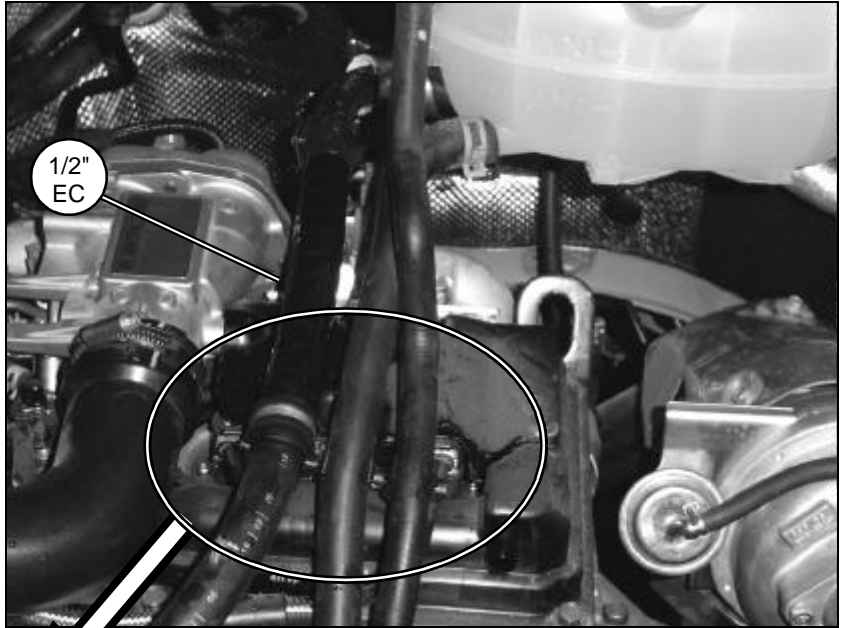

**ELEMENTI DI FISSAGGIO / PIECES DE FIXATION
FIXING PARTS / BEFESTIGUNGSELEMENTE
ELEMENTOS DE FIJACION**

Pos.	Tipologia Typologie Typology Tipologie Tipologia	Descrizione Description Description Beschreibung Descripción	Codice Code Kode Codigo
48		Fermatubo ϕ 24	069637/0
50		Fermatubo ϕ 18	069635/0

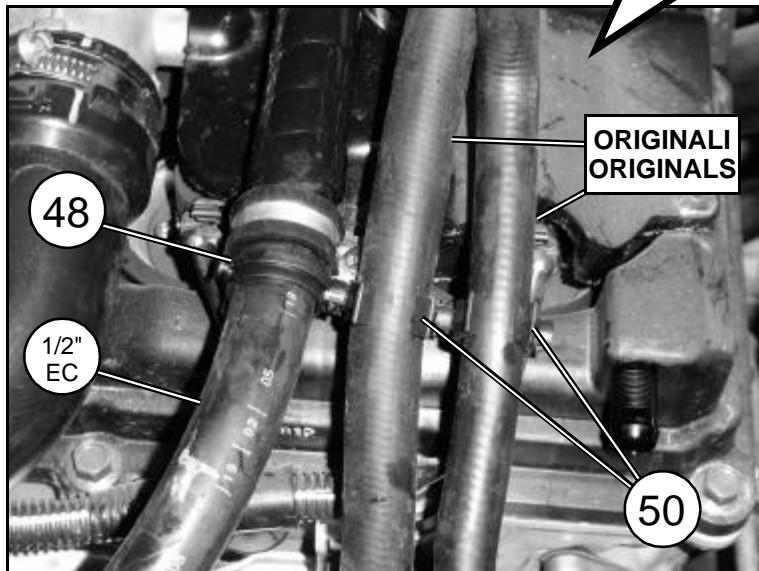

12E

ELEMENTI DI FISSAGGIO / PIÈCES DE FIXATION FIXING PARTS / BEFESTIGUNGSELEMENTE ELEMENTOS DE FIJACION			
Pos.	Tipologia Typologie Typology Tipologie Tipologia	Descrizione Description Description Beschreibung Descripción	Codice Code Code Kode Codigo
48		Fermatubo ϕ 24	069637/0
49		Fermatubo ϕ 22	069636/0

13E

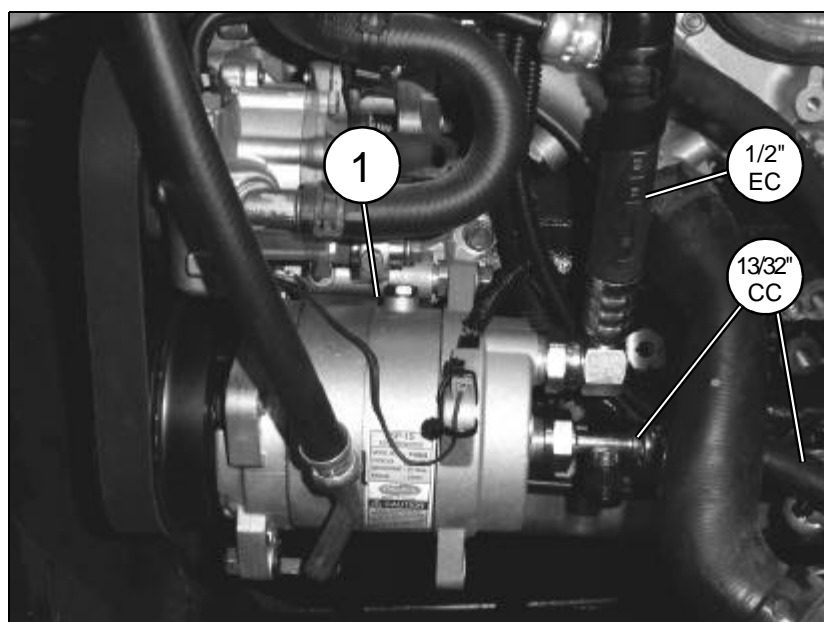
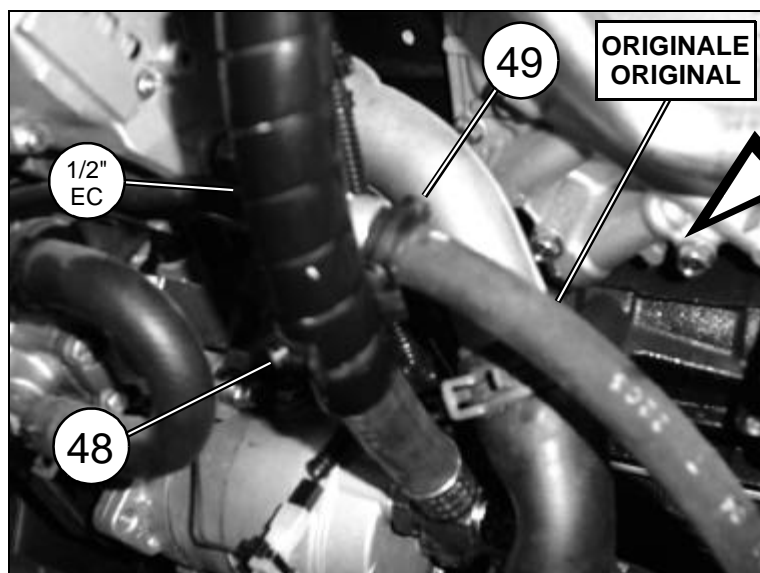

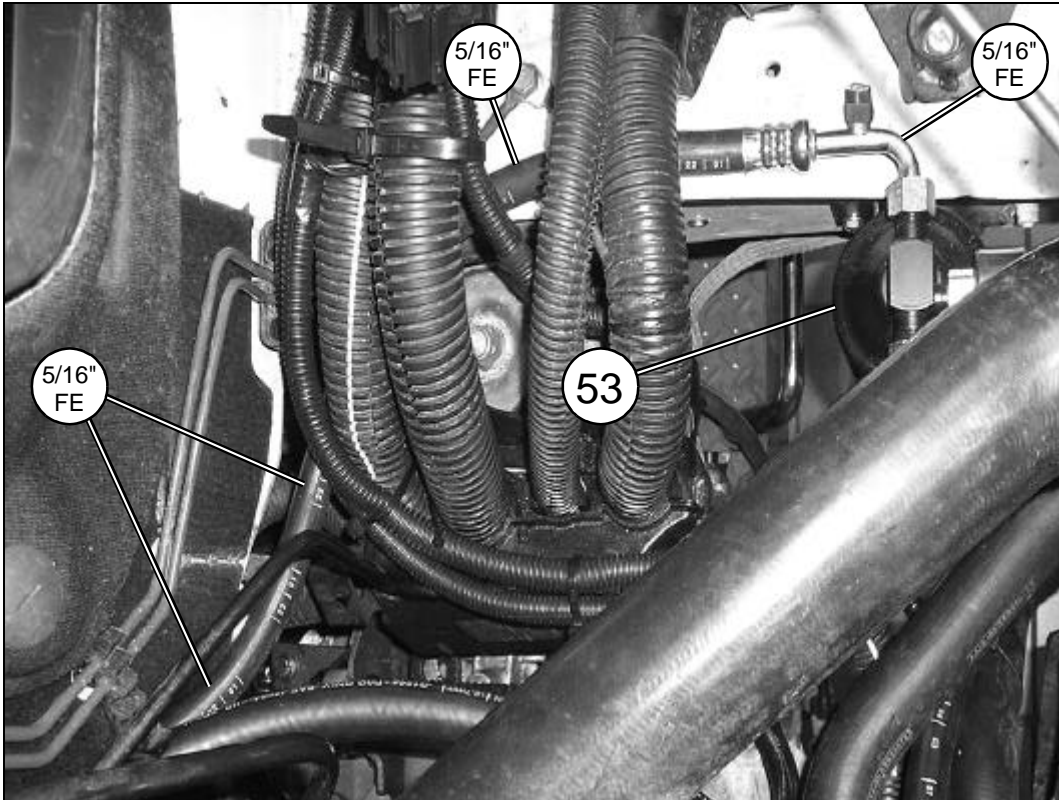

14E

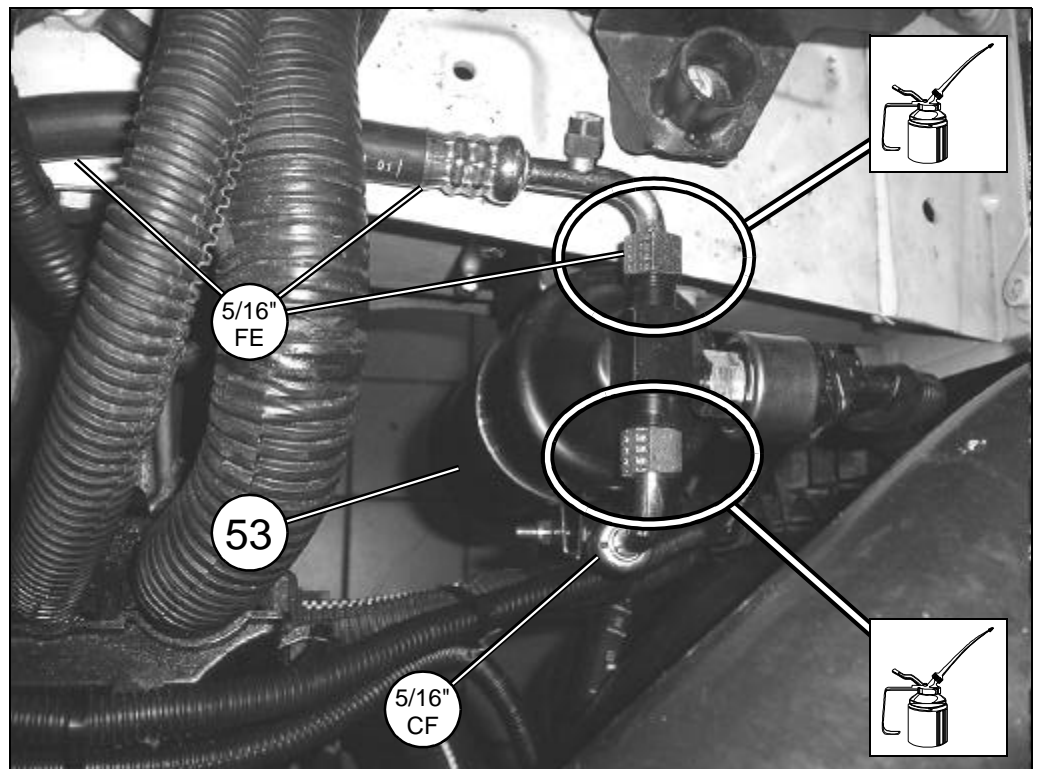

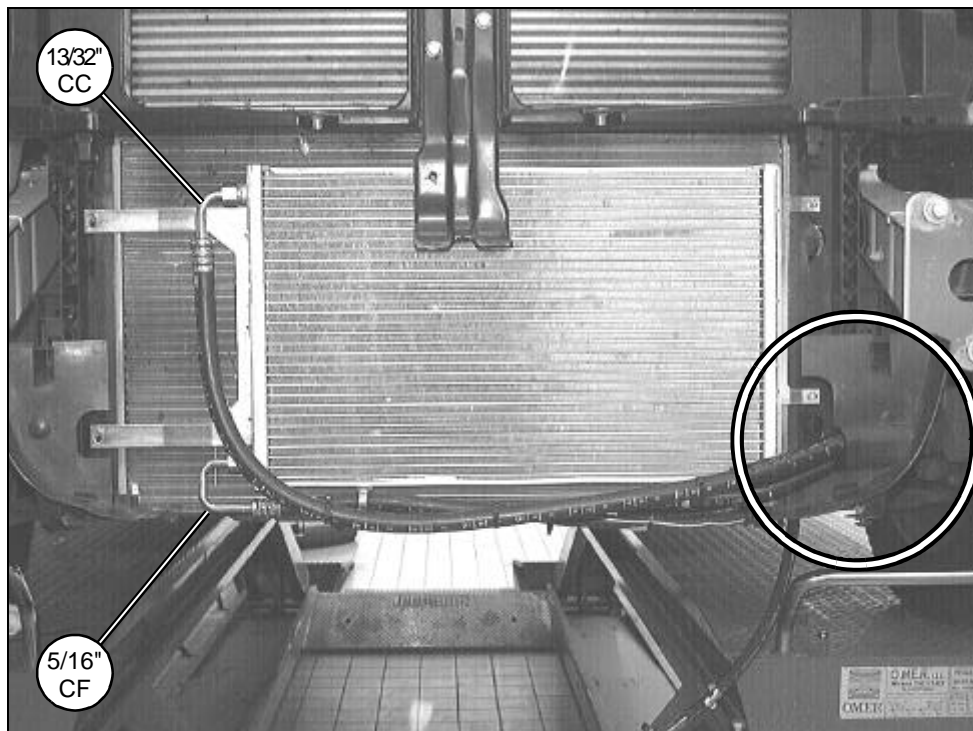

15E

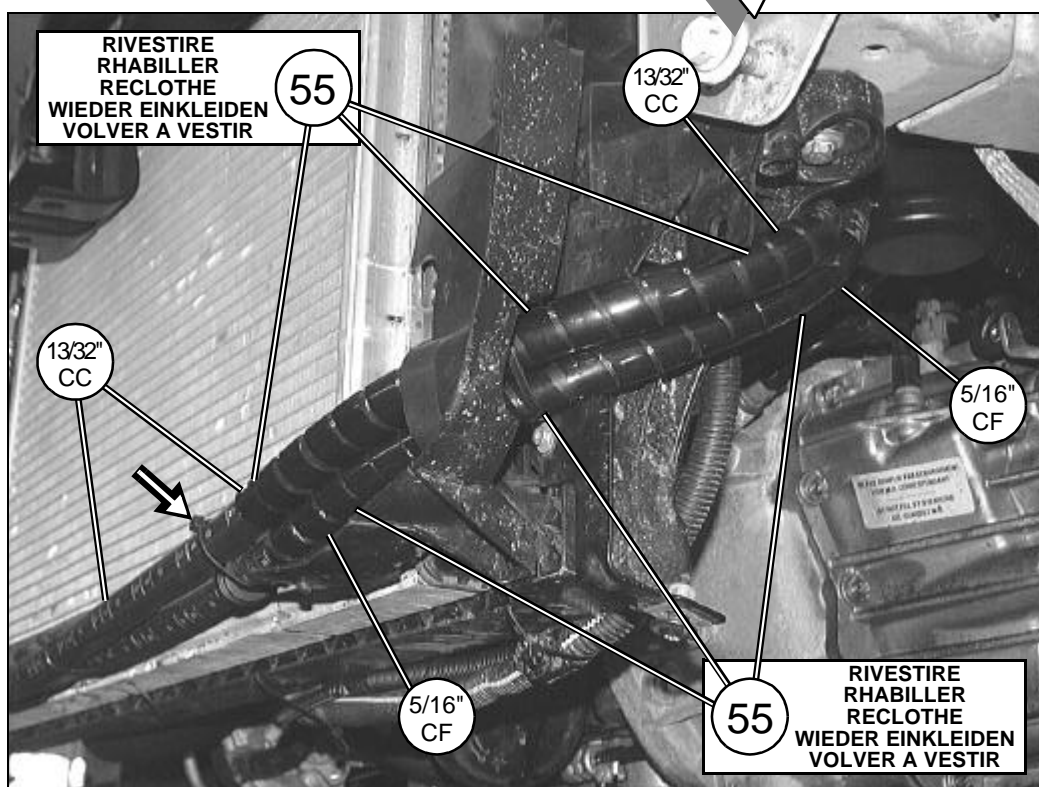

ELEMENTI DI FISSAGGIO / PIÈCES DE FIXATION / FIXING PARTS BEFESTIGUNGSELEMENTE / ELEMENTOS DE FIJACION		
Pos.	Tipologia / Typologie / Typology Tipologie / Tipologia	Descrizione / Description / Description Beschreibung / Descripción
		Fascetta a strappo

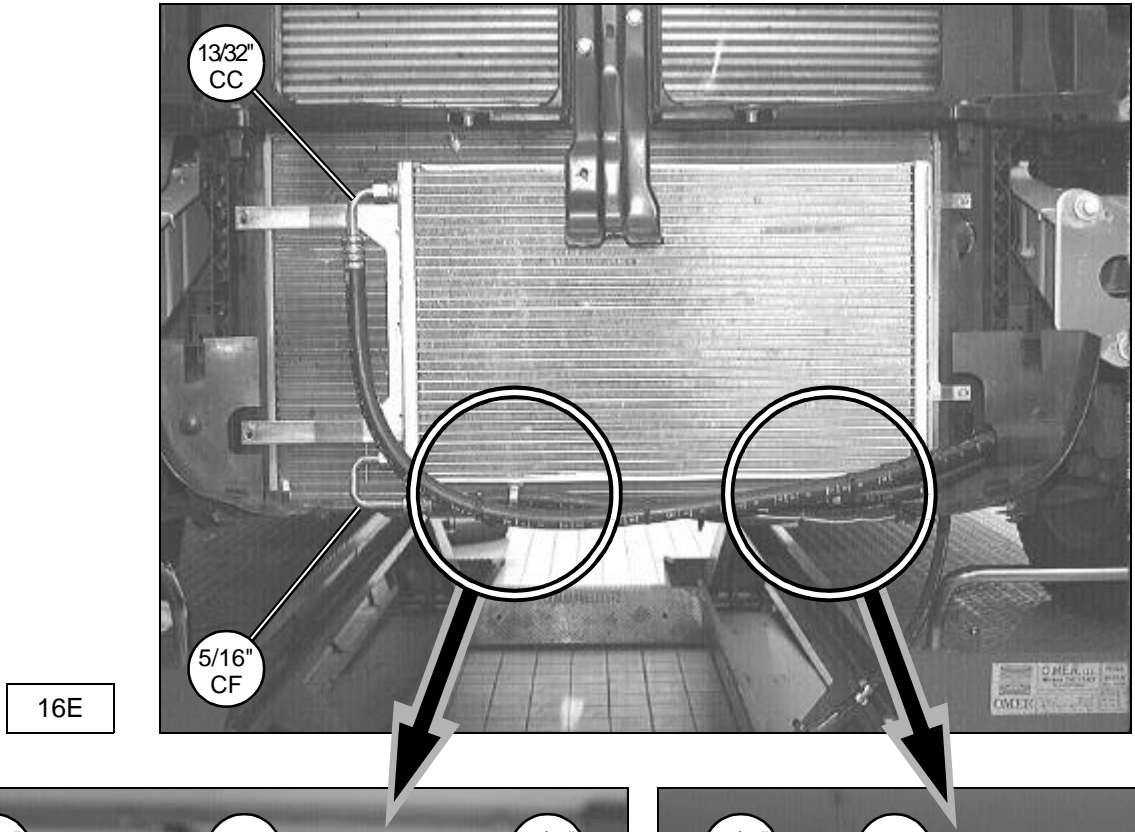

16E

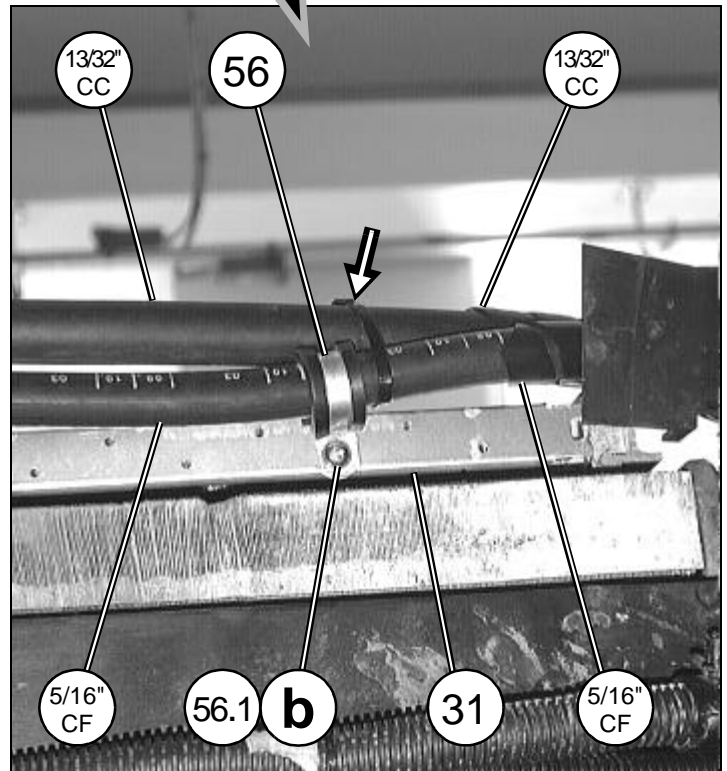
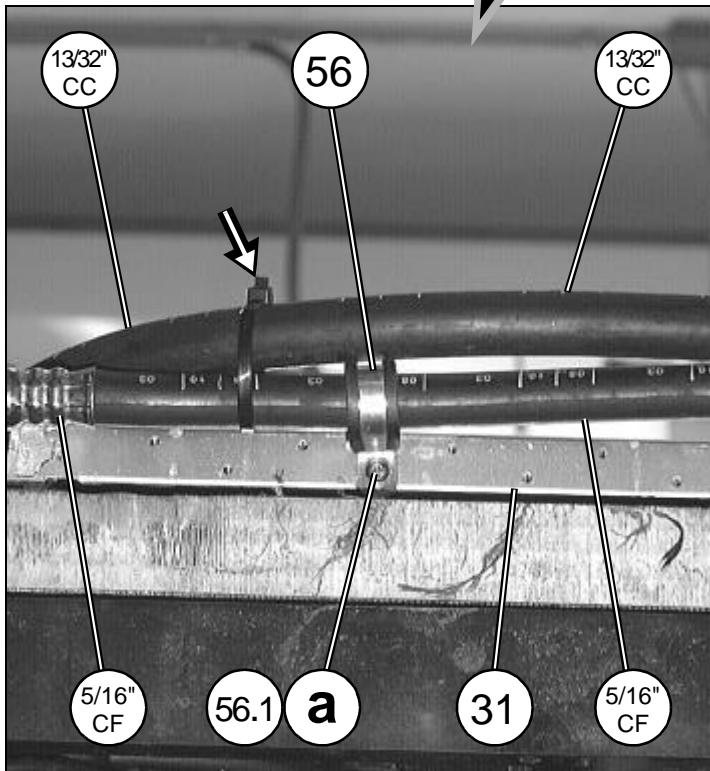

ELEMENTI DI FISSAGGIO / PIECES DE FIXATION / FIXING PARTS BEFESTIGUNGSELEMENTE / ELEMENTOS DE FIJACION		
Pos.	Tipologia / Typologie / Typology Tipologie / Tipologia	Descrizione / Description / Description Beschreibung / Descripción
56.1		4,2x9,5
		Fascetta a strappo

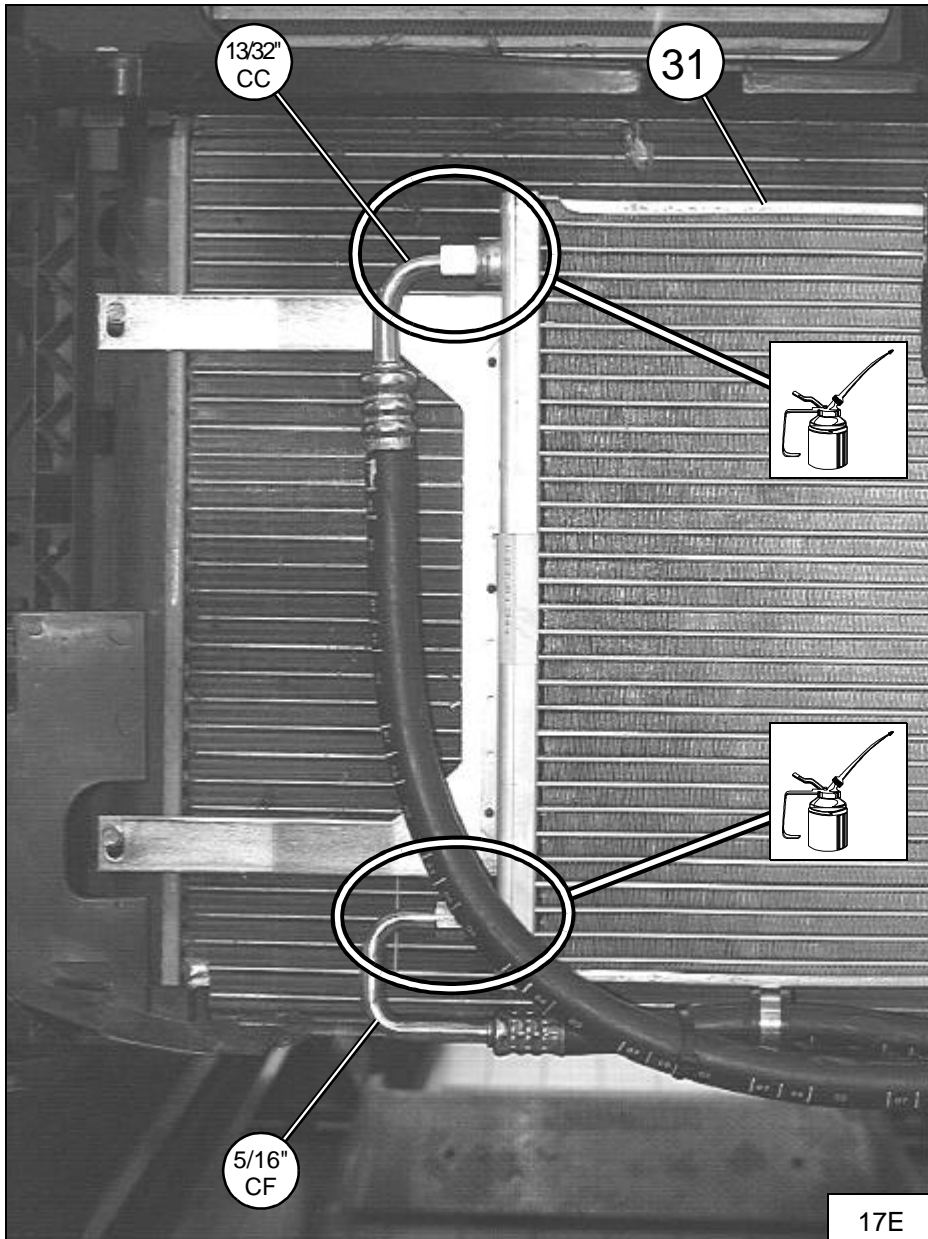

**SCHEMA IMPIANTO ELETTRICO / SCHEMA DE L'INSTALLATION ELECTRIQUE / WIRING DIAGRAM
SCHEMA DER ELEKTRISCHEN ANLAGE / ESQUEMA INSTALACION ELECTRICA
RENAULT MASTER / OPEL MOVANO 2.2-2.5-3.0 CDI**

0282374/1

26-04-05

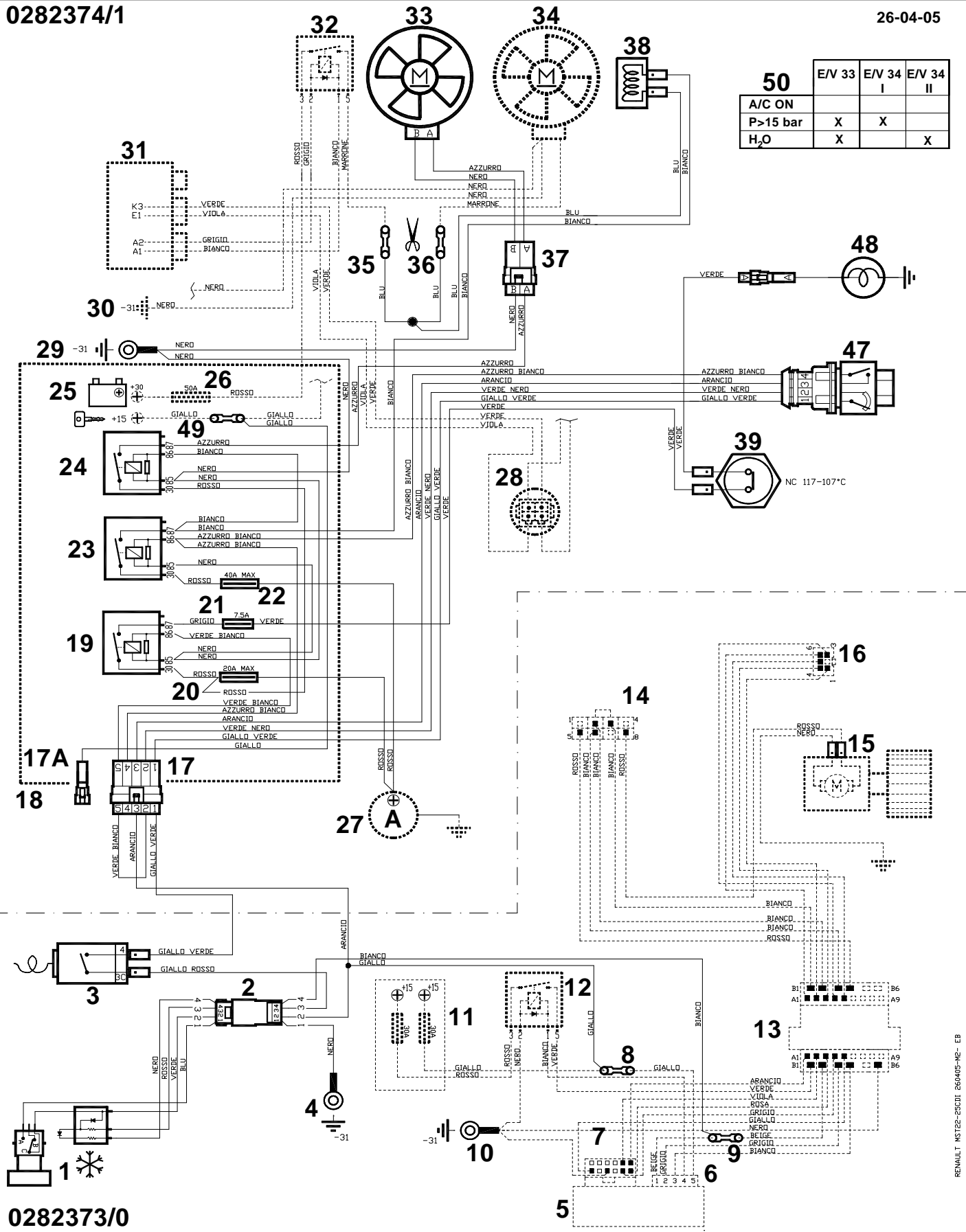

0282373/0

N.	Descrizione / Description / Description Beschreibung / Descripción	Funzione / Fonction / Function Funktion / Función
1	Interruttore A/C Interrupteur A/C A/C switch Klimaanlagen-Schalter Interruptor A/C	
2	Connettore 4 vie / Connecteur à 4 voies 4-way connector / 4-weg-Steckverbinder Conector 4 vías	
3	Termostato antighiaccio Thermostat antigivrage No frost thermostat Abtau-Thermostat Termostato anti-escarcha	
4	Anello di massa / Bague de masse Ground ring / Masse-ösen-Anschluß Terminal a anillo de masa	
5	Plancia comandi / Partiel tableau commandes Control panel / Instrumententafel-Steuerung Placa de los mandos	
6	Connettore 5 via / Connecteur à 5 voie 5-way connector / 5-weg-Steckverbinder Conector 5 vía	
7	Connettore 12 via / Connecteur à 12 voie 12-way connector / 12-weg-Steckverbinder Conector 12 vía	
8	Giunzione RAYCHEM BLU Raccord RAYCHEM BLEU BLUE RAYCHEM connector RAYCHEM Verbindung BLAU Junta RAYCHEM TURQUI	Collegamento con +CHIAVE (+15) Connexion avec (+15) Connection with (+15) Anschluß mit (+15) Conexión con (+15)
9	Giunzione RAYCHEM GIALLO Raccord RAYCHEM JAUNE YELLOW RAYCHEM connector RAYCHEM Verbindung GELB Junta RAYCHEM AMARILLO	Collegamento con 1° velocità di ventilazione Connexion avec 1° vitesse de ventilation Connection to the 1st fan speed Anschluß mit der 1. Lüftungsgeschwindigkeit Conexión con 1° velocidad ventilación
10	Punto di massa originale Point de masse d'origine Original ground point Original-Massepunkt Punto de masa original	
11	Scatola porta fusibili / Boîte à fusibles Fuse box / Schmelzsicherungskasten Caja porta-fusibles	
12	Relay interruttore 30A / Relais de coupure 30A 30A Switch Relay / Relais-Schalter 30A Relé interruptor 30A	
13	Connettore 15 via / Connecteur à 15 voie 15-way connector / 15-weg-Steckverbinder Conector 15 vía	
14	Resistore / Résistance / Resistor Widerstand / Resistor	
15	Elettroventola abitacolo Pulseur de l'habitacle Passenger compartment air blower Elektrolüfter im Fahrzeuginnenraum Electroventilador del habitáculo	
16	Connettore 6 via / Connecteur à 6 voie 6-way connector / 6-weg-Steckverbinder Conector 6 vía	
17	Connettore 5 via Connecteur à 5 voie 5-way connector 5-weg-Steckverbinder Conector 5 vía	Collegamento impianto elettrico vano motore con impianto elettrico interno vettura Connexion du faisceau électrique du logement moteur au faisceau électrique interne de la voiture Connection of the engine compartment electric wiring to the car inner electric wiring Anschluß der Elektroanlage im Motorraum mit Elektroanlage im Fahrzeuginnenen Conexión de la instalación eléctrica de la sede del motor con la instalación eléctrica del interior del coche

17A	Connettore 1 via / Connecteur à 1 voie 1-way connector / 1-weg-Steckverbinder Conector 1 vía	
18	Scatola porta relay / Boîte à relais / Relay box Relaiskasten / Caja porta-relé	
19	Relay interruttore 30A Relais de coupure 30A 30A Switch Relay Relais-Schalter 30A Relé interruptor 30A	Comando giunto elettromagnetico compressore Commande l'embrayage électromagnétique du compresseur Compressor electromagnetic clutch control Steuerung der elektromagnetischen Kupplung des Kompressors Comando junta electromagnética compresor
20	Fusibile 20A Max / Fusible 20A Max 20A Max Fuse / Schmelzsicherung 20A Max Fusible 20A Max	
21	Fusibile 7.5A / Fusible 7.5A / 7.5A Fuse Schmelzsicherung 7.5A / Fusible 7.5A	
22	Fusibile 40A Max / Fusible 40A Max 40A Max Fuse / Schmelzsicherung 40A Max Fusible 40A Max	
23	Relay interruttore 70A Relais de coupure 70A 70A Switch Relay Relais-Schalter 70A Relé interruptor 70A	Comando elettroventola n. 34 (1. Velocità) Commande électroventilateur n. 34 (1e vitesse) Controls electric fan no. 34 (1st speed) Elektrolüftersteuerung N. 34 (1. Geschwindigkeitsstufe) Comando electroventilador n. 34 (1° velocidad)
24	Relay interruttore 30A Relais de coupure 30A 30A Switch Relay Relais-Schalter 30A Relé interruptor 30A	Comando elettroventola n. 33 Commande électroventilateur n. 33 Controls electric fan no. 33 Elektrolüftersteuerung N. . 33 Comando electroventilador n.33
25	Batteria / Batterie / Battery / Batterie / Bateria	
26	Fusibile 50A Max / Fusible 50A Max 50A Max Fuse / Schmelzsicherung 50A Max Fusible 50A Max	
27	Alternatore / Alternateur / Alternator Drehstromgenerator / Alternador	
28	Bulbo termostatico / Bulbe thermostatique Thermoswitch / Thermostat-Schalter Bulbo termostático	
29	Anello di massa / Bague de masse Ground ring / Masse-ösen-Anschluß Terminal a anillo de masa	
30	Punto di massa originale Point de masse d'origine Original ground point Original-Massepunkt Punto de masa original	
31	Centralina IE Dispositif de contrôle à injection électronique Electronic injection box unit Elektronisches Einspritzgehäuse Centralita IE	
32	Relay interruttore 30A Relais de coupure 30A 30A Switch Relay Relais-Schalter 30A Relé interruptor 30A	Comando elettroventola n. 34 (2. Velocità) Commande électroventilateur n. 34 (2e vitesse) Controls electric fan no. 34 (2st speed) Elektrolüftersteuerung N. 34 (2. Geschwindigkeitsstufe) Comando electroventilador n. 34 (2° velocidad)
33	Elettroventola Electroventilateur Fan Elektrolüfter Electroventilador	Raffreddamento radiatore e condensatore Refroidissement radiateur et condenseur Radiator and condenser cooling Kühler- und Kondensatorkühlung Enfriamiento radiator y condensador
34	Elettroventola Electroventilateur Fan Elektrolüfter Electroventilador	Raffreddamento radiatore e condensatore Refroidissement radiateur et condenseur Radiator and condenser cooling Kühler- und Kondensatorkühlung Enfriamiento radiator y condensador
35	Giunzione RAYCHEM GIALLO Raccord RAYCHEM JAUNE YELLOW RAYCHEM connector RAYCHEM Verbindung GELB Junta RAYCHEM AMARILLO	

36	Giunzione RAYCHEM GIALLO Raccord RAYCHEM JAUNE YELLOW RAYCHEM connector RAYCHEM Verbindung GELB Junta RAYCHEM AMARILLO	
37	Connettore 2 via / Connecteur à 2 voie 2-way connector / 2-weg-Steckverbinder Conector 2 vía	
38	Resistore / Résistance / Resistor Widerstand / Resistor	
39	Bulbo termostatico Bulbe thermostatique Thermoswitch Thermostat-Schalter Bulbo termostático	Comando disinserimento giunto elettromagnetico compressore con temperatura acqua 97°C Commande le déclenchement de l'embrayage électromagnétique du compresseur avec température de l'eau à 97°C Cuts out the compressor electromagnetic clutch with water temperature at 97°C Ausschaltung-Steuerung der elektromagnetischen Kupplung des Kompressors mit 97°C Wassertemperatur Comando desinserción junta electromagnética compresor con temperatura de agua 97°C
47	Pressostato / Pressostat / Pressure switch Druckwächter / Presostato	
48	Giunto elettromagnetico compressore Embrayage électromagnétique du compresseur Compressor electromagnetic clutch Elektromagnetische Kupplung des Kompressors Junta electromagnética del compresor	
49	Giunzione RAYCHEM BLU Raccord RAYCHEM BLEU BLUE RAYCHEM connector RAYCHEM Verbindung BLAU Junta RAYCHEM TURQUI	Collegamento con +CHIAVE (+15) Connexion avec (+15) Connection with (+15) Anschluß mit (+15) Conexión con (+15)
50	Logica funzionamento elettroventole Logique fonctionnement électroventilateurs Electric fan logic Betriebslogik der Elektrolüfter Logica funcionamiento electroventiladores	

(I)

N.B.:

Le parti in tratteggio rappresentano componenti dell'impianto elettrico originale.

(F)

N.B.:

Les parties hachurées représentent des composants du faisceau électrique d'origine.

(GB)

N.B.:

The dashed parts represent components of the original electric system.

(D)

N.B.:

Die gestrichelten Teile stellen Bauteile der ursprünglichen Anlage dar.

(E)

N.B.:

Les partes discontinuas representan componentes de la instalación eléctrica original.

ITALIANO	FRANCAIS	ENGLISH	DEUTSCH	ESPAÑOL
Arancio	Orange	Orange	Orange	Naranja
Azzurro	D'azur	Light blue	Hellblau	Azul
Bianco	Blanc	White	Weiss	Blanco
Blu	Bleu	Blue	Blau	Turqui
Giallo	Jaune	Yellow	Gelb	Amarillo
Grigio	Gris	Gray	Grau	Gris
Marrone	Marron	Brown	Braun	Marron
Nero	Noir	Black	Schwarz	Negro
Rosa	Rose	Pink	Rosa	Rosa
Rosso	Rouge	Red	Rot	Rojo
Verde	Vert	Green	Grün	Verde
Viola	Violet	Violet	Violett	Violado

(I)
DELPHI ITALIA mira ad un costante miglioramento dei propri prodotti. La Casa si riserva il diritto di apportare in qualunque momento e senza preavviso modifiche ai modelli e ai componenti descritti in questa pubblicazione per ragioni di natura tecnica o commerciale. Per ulteriori informazioni rivolgersi al servizio assistenza DELPHI.

(F)
DELPHI ITALIA vise à une amélioration constante des ces produits. La maison se réserve le droit d'apporter, à tout moment et sans préavis, des modifications aux modèles et aux composants décrits dans cette publication pour des raisons d'ordre technique ou commerciale. Pour d'ultérieures informations s'adresser au service d'assistance DELPHI.

(GB)
DELPHI ITALIA focuses on constant upgrading of its products. The Manufacturer reserves the right to modify the models and components described in the present publication at any time for technical or commercial reasons and without prior notice. For further information, contact DELPHI technical services.

(D)
DELPHI ITALIA ist stets bestrebt die eigenen Produkte zu verbessern. Die Herstellerfirma behält sich das Recht vor, aus technischen oder Verkaufsgründen, zu jeder Zeit und ohne vorherige Ankündigung, Abänderungen an den Modellen und den in dieser Veröffentlichung beschriebenen Einbauteile vorzunehmen. Für weitere Informationen bitten wir Sie, sich an unseren DELPHI Kundendienst zu wenden.

(E)
DELPHI ITALIA aspira a un constante mejoramiento de su producción. La Fábrica se reserva el derecho de aportar en cualquier momento y sin preaviso modificaciones a los modelos y los componentes descritos en esta publicación por razones técnicas o comerciales. Para ultiores informaciones dirigirse al servicio asistencia DELPHI.

VENDITA E SERVIZIO
VENTE ET SERVICE

VERKAUF UND SERVICE
SALE AND SERVICE

DELPHI ITALIA AUTOMOTIVE SYSTEMS S.r.l.
Stabilimento Molinella

Via Nobili, 2 40062 Molinella (Bologna)-Italy
Telefono (0039) 051.6906111
Fax (0039) 051.6906287

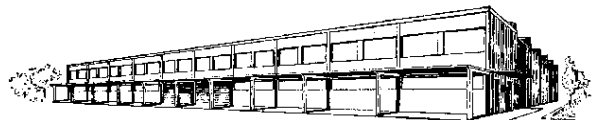

MOD. SCHRE233

VII / '05
(2005)

Questa pubblicazione è stata curata da DELPHI ITALIA-Diavia
Ufficio Fitting Instructions - Stabilimento Molinella

This publication has been edited by DELPHI ITALIA-Diavia
Fitting Instructions Office - Factory Molinella